

For Compact Weather Stations Part Numbers:-

1957-0100-60-XX0 1957-0200-60-XX0 1957-0300-60-XX0 1957-0301-60-XX0

1957-0400-60-XX0 1957-0500-60-XX0 1957-0501-60-XX0 1957-0600-60-XX0

Doc No: 1957-PS-001

Issue 8 Applies to Units with Firmware 2669 V1.03.02



GMX100



GMX200



GMX300



GMX301



GMX400



GMX500



GMX501



GMX600

---

 Contents

<b>1.</b>	<b>FOREWORD.....</b>	<b>5</b>
<b>2.</b>	<b>INTRODUCTION.....</b>	<b>5</b>
2.1.	MaxiMet Part Numbers and Parameters .....	5
2.1.1	MaxiMet Part Numbers with V1.XX.XX Firmware. ....	5
2.1.2	MaxiMet Sensors and Derived Parameters Table.....	6
2.1.3	Wind Speed and Direction Sensor (GMX200, GMX500, GMX501 and GMX600).....	7
2.1.4	Solar Radiation Shield (GMX300, GMX 301, GMX400, GMX500, GMX501 and GMX600).....	7
2.1.5	Barometric Pressure (GMX300, GMX301, GMX400, GMX500, GMX501 and GMX600).....	8
2.1.6	Temperature, Relative Humidity and Dewpoint (GMX300, GMX301, GMX400, GMX500, GMX501 and GMX600) .....	8
2.1.7	Rain (GMX100, GMX400 and GMX600) .....	8
2.1.8	Compass (GMX200, GMX500, GMX501 and GMX600) .....	8
2.1.9	Compass Declination.....	8
2.1.10	Solar (GMX301 and GMX501) .....	8
2.1.11	GPS Option (GMX200, GMX500, GMX501 and GMX600) .....	8
2.1.12	MaxiMet Output Parameters selectable using MetSet Software.....	9
2.2.	GMX Sensor Default ASCII Output Summary .....	16
<b>3.</b>	<b>TECHNICAL SPECIFICATION.....</b>	<b>18</b>
<b>4.</b>	<b>PRE-INSTALLATION .....</b>	<b>21</b>
4.1.	Equipment supplied .....	21
4.1.2	Optional Extras: .....	21
4.2.	Connector and Cable Assembly.....	21
4.3.	Cabling .....	24
4.3.1	Cable type .....	24
4.3.2	Cable length .....	24
4.4.	Connections.....	25
4.4.1	View of the MaxiMet connector .....	25
4.4.2	9 way connector and cable connections.....	25
4.5.	Power supplies .....	25
4.5.1	MaxiMet units .....	25
4.6.	Connecting to a PC using RS232 (Default setting).....	26
4.7.	Connecting to a PC using RS422 (Not a Default Setting).....	26
4.8.	Using RS485 (not a default setting). .....	27
4.9.	Using SDI-12 (2 wire network) not a default setting.....	27
4.10.	Set up requirements .....	28
4.10.1	Host System: .....	28
4.10.2	Software: .....	28
4.10.3	Bench system test .....	28
4.11.	Packaging.....	28
<b>5.</b>	<b>INSTALLATION.....</b>	<b>29</b>
5.1.	General Installation Guidelines .....	29
5.1.1	Interference .....	29
5.1.2	Wind.....	29
5.1.3	Compass .....	30
5.1.4	GPS .....	30
5.1.5	Solar.....	30
5.1.6	Rain .....	30
5.1.7	General Alignment.....	31
5.1.8	Mounting Tube e.g. Gill Part 1405-30-056.....	31
5.1.9	Mounting Bracket e.g. Gill Part 1771-PK-115 .....	31

5.1.10	Dimensions (in mm).....	33
<b>6.</b>	<b>CONFIGURING WITH METSET .....</b>	<b>35</b>
6.1.	MaxiMet Default Configurations.....	35
6.2.	Configuring MaxiMet with MetSet.....	43
6.2.1	Opening MetSet.....	43
6.2.2	MetSet Editing Screen .....	45
6.2.3	MetSet Online Settings.....	46
6.2.4	MetSet Editing Pages.....	47
6.2.5	WMO Average Wind Reading Notes: .....	49
6.3.	Polled Mode.....	56
6.4.	Configuring MaxiMet for SDI-12.....	57
6.4.1	SDI-12 Units of Measure.....	57
6.4.2	SDI-12 Commands.....	58
6.4.3	SDI-12 Commands with CRC .....	60
6.5.	Configuring MaxiMet for MODBUS .....	62
6.5.1	MaxiMet Supported Modbus Specification.....	62
6.6.	Configuring MaxiMet for NMEA Output .....	70
6.6.1	GMX100 NMEA Output String.....	70
6.6.2	GMX200 NMEA Output String.....	71
6.6.3	GMX300 NMEA Output String.....	72
6.6.4	GMX301 NMEA Output String.....	72
6.6.5	GMX400 NMEA Output String.....	73
6.6.6	GMX500 NMEA Output String.....	73
6.6.7	GMX501 NMEA output String .....	75
6.6.8	GMX600 NMEA Output String.....	76
6.7.	Safe Mode .....	79
6.7.1	Summary.....	79
6.7.2	Safe Mode Method 1 .....	79
6.7.3	Safe Mode Method 2 .....	82
6.8.	Using a Terminal Program to Set MaxiMet Date and Time .....	84
<b>7.</b>	<b>VIEWING MAXIMET DATA STRING.....</b>	<b>85</b>
7.1.	Use MetSet to View the MaxiMet Data String .....	85
7.2.	Using Gill MetView Software to View the MaxiMet Data String. ....	86
7.2.1	Opening MetView .....	86
7.2.2	Scanning for Devices.....	87
7.2.3	The MetView Console.....	88
7.2.4	MetView Console Display Options .....	89
7.2.5	MetView Gauge Ranges and Graphs.....	90
7.2.6	Data logging .....	92
7.3.	Use a Terminal Program to View the MaxiMet Data String .....	93
<b>8.</b>	<b>MAINTENANCE &amp; FAULT-FINDING .....</b>	<b>96</b>
8.1.	Cleaning and Handling.....	96
8.2.	Servicing.....	96
8.2.1	Precipitation Sensor.....	96
8.2.2	Solar Sensor.....	96
8.2.3	Compass/GPS modules.....	97
8.2.4	Wind Sensor (WindSonic).....	97
8.2.5	Barometer .....	97
8.2.6	UV Shield (MetSpec) .....	97
8.2.7	Temperature, Humidity and Dewpoint .....	97
8.2.8	Calibration.....	97
8.2.9	Returning the MaxiMet.....	97
8.3.	Fault-finding.....	98
8.4.	Safe Mode .....	99

8.5.	Bench Test .....	99
8.6.	Returning Units.....	99
8.7.	Guarantee.....	99
<b>9.</b>	<b>APPENDICES.....</b>	<b>100</b>
9.1.	Glossary & Abbreviations.....	100
9.2.	Electrical Conformity.....	101

# 1. FOREWORD

Thank you for purchasing the MaxiMet manufactured by Gill Instruments Ltd. To achieve optimum performance we recommend that you read the whole of this manual before proceeding with use.

Gill products are in continuous development and therefore specifications may be subject to change and design improvements without prior notice.

The information contained in this manual remains the property of Gill Instruments and must not be copied or reproduced for commercial gain.

# 2. INTRODUCTION

The Gill MaxiMet sensor units are very robust with no moving parts. The sensor units, output rate and formats are all user selectable.

The MaxiMet can be used in conjunction with a PC, data logger or other device.

The MaxiMet combines all the instrument data into a single data string. This may be configured for digital ASCII RS232/RS422/RS485 (2 wire point to point only), digital MODBUS RTU/ASCII, NMEA and SDI-12 outputs.

## 2.1. MaxiMet Part Numbers and Parameters

### 2.1.1 MaxiMet Part Numbers with V1.XX.XX Firmware.

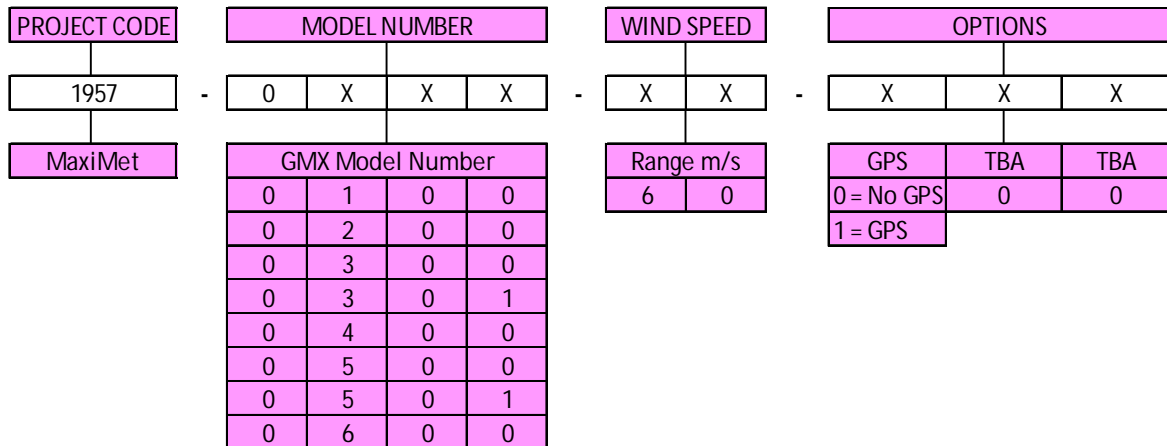

NOTE: For information within the part structure:-

1957-0XXX-XX-XXX

X – A number greater than 0 identifies the unit to have a Solar Sensor fitted.

**2.1.2 MaxiMet Sensors and Derived Parameters Table.**

<b>GMX Sensor Parameter</b>	<b>100</b>	<b>300</b>	<b>301</b>	<b>400</b>	<b>200</b>	<b>500</b>	<b>501</b>	<b>600</b>
Wind Speed, Relative	NA	NA	NA	NA	■	■	■	■
Wind Direction, Relative	NA	NA	NA	NA	■	■	■	■
Compass, Heading	NA	NA	NA	NA	■	■	■	■
Temperature, Air	NA	■	■	■	NA	■	■	■
Humidity, Relative	NA	■	■	■	NA	■	■	■
Barometric Pressure	NA	■	■	■	NA	■	■	■
Rain/Precipitation (built in)	■	NA	NA	■	NA	NA	NA	■
Solar Radiation	NA	NA	■	NA	NA	NA	■	NA
GPS (option)	NA	NA	NA	NA	Opt	Opt	Opt	Opt
<b>GMX Derived Parameter</b>	<b>100</b>	<b>300</b>	<b>301</b>	<b>400</b>	<b>200</b>	<b>500</b>	<b>501</b>	<b>600</b>
Average Speed (WMO)	NA	NA	NA	NA	■	■	■	■
Average Direction (WMO)	NA	NA	NA	NA	■	■	■	■
Average Corrected Direction (WMO)	NA	NA	NA	NA	■	■	■	■
Corrected Direction	NA	NA	NA	NA	■	■	■	■
Gust Direction (WMO)	NA	NA	NA	NA	■	■	■	■
Gust Speed (WMO)	NA	NA	NA	NA	■	■	■	■
Status (Sensors)	NA	■	■	■	■	■	■	■
Wind Status	NA	NA	NA	NA	■	■	■	■
Dewpoint	NA	■	■	■	NA	■	■	■
Absolute Humidity	NA	■	■	■	NA	■	■	■
Pressure at Sea Level	NA	■	■	■	NA	■	■	■
Pressure at Station	NA	■	■	■	NA	■	■	■
Precipitation Intensity	■	NA	NA	■	NA	NA	NA	■
Precipitation Total	■	NA	NA	■	NA	NA	NA	■
Precipitation Status	NA	NA	NA	■	NA	NA	NA	■
Solar (sunshine) Hours	NA	NA	■	NA	NA	NA	■	NA
Node Letter	■	■	■	■	■	■	■	■
Volts (Supply)	■	■	■	■	■	■	■	■
Time (and Date)	■	■	■	■	■	■	■	■
Corrected Speed	NA	NA	NA	NA	GPS Opt	GPS Opt	GPS Opt	GPS Opt
Average Corrected Speed (WMO)	NA	NA	NA	NA	GPS Opt	GPS Opt	GPS Opt	GPS Opt
Corrected Gust Speed	NA	NA	NA	NA	GPS Opt	GPS Opt	GPS Opt	GPS Opt
Corrected Gust Direction	NA	NA	NA	NA	GPS Opt	GPS Opt	GPS Opt	GPS Opt
GPS Location (Longitude/Latitude)	NA	NA	NA	NA	GPS Opt	GPS Opt	GPS Opt	GPS Opt
GPS Heading	NA	NA	NA	NA	GPS Opt	GPS Opt	GPS Opt	GPS Opt
GPS Speed	NA	NA	NA	NA	GPS Opt	GPS Opt	GPS Opt	GPS Opt
GPS Status	NA	NA	NA	NA	GPS Opt	GPS Opt	GPS Opt	GPS Opt
■ = Standard Fitted, NA = Not Available, Opt = Optional, Ext = use customer supplied Rain Gauge								

### 2.1.3 Wind Speed and Direction Sensor (GMX200, GMX500, GMX501 and GMX600)

The MaxiMet uses the Gill WindSonic wind speed and direction sensor. The WindSonic measures the times taken for an ultrasonic pulse of sound to travel from the North (N) transducer to the South (S) transducer, and compares it with the time for a pulse to travel from S to N transducer. Likewise times are compared between West (W) and East (E), and E and W transducer.

If, for example, a North wind is blowing, then the time taken for the pulse to travel from N to S will be faster than from S to N, whereas the W to E, and E to W times will be the same. The wind speed and direction can then be calculated from the differences in the times of flight on each axis. This calculation is independent of factors such as temperature.

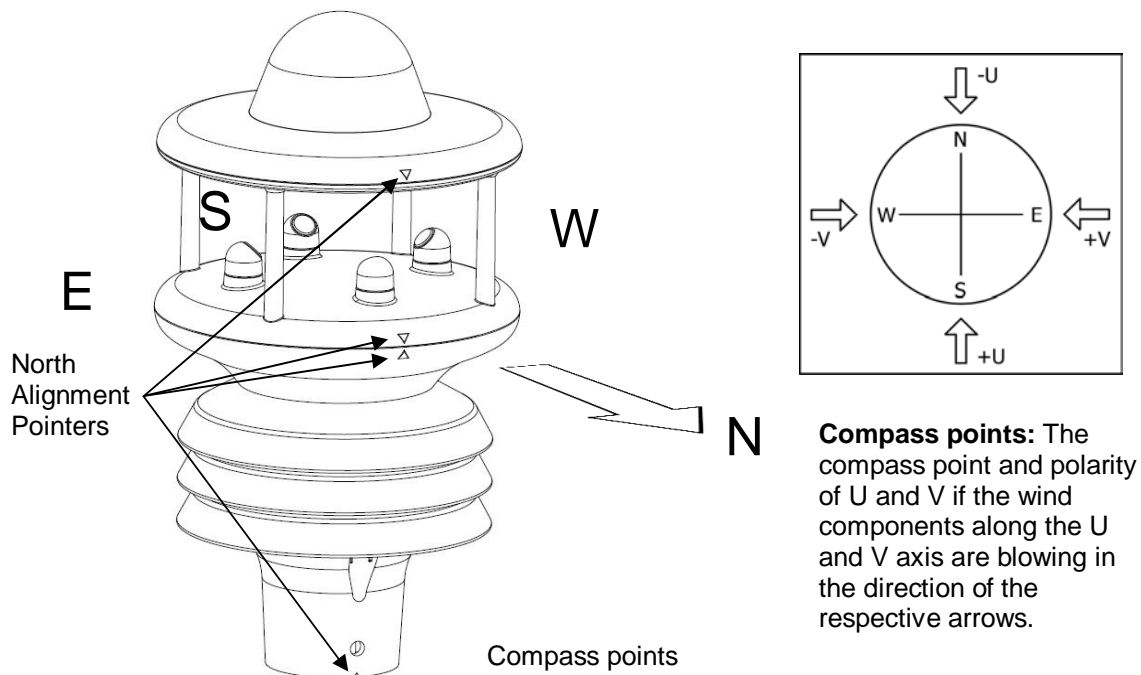

MaxiMet can output the following wind readings depending on use of a Compass or GPS.

Relative wind – wind speed and/or direction, uncorrected, but relative to the north marker, which may not be facing North.

Corrected wind – with the aid of the Compass Magnetic North corrected wind direction can be output.

True wind – wind speed and/or direction information corrected by GPS for any direction misalignment of the north marker and/or for any motion of the station. (E.g. vehicle or vessel).

### 2.1.4 Solar Radiation Shield (GMX300, GMX 301, GMX400, GMX500, GMX501 and GMX600)

A MetSpec Multi-Plate Solar Radiation Shield is used. The special shield plate geometry, with its double louvre design, provides excellent response time performance of quick ambient temperature changes while still working effectively as a baffle to stop larger contaminants such as salt or dirt from reaching the temperature and humidity sensor. The shield benefits from very robust material choice and extremely high UV protection requiring no maintenance.



### **2.1.5 Barometric Pressure (GMX300, GMX301, GMX400, GMX500, GMX501 and GMX600)**

Barometric pressure output is provided by a solid-state device fitted on to a circuit board inside a MaxiMet moulding.

### **2.1.6 Temperature, Relative Humidity and Dewpoint (GMX300, GMX301, GMX400, GMX500, GMX501 and GMX600)**

There is internal solid state sensor circuitry contained within the Radiation shield that provides digital output signals for Relative Humidity, Temperature and calculated Dewpoint.

### **2.1.7 Rain (GMX100, GMX400 and GMX600)**

Rain drop detection and a reading of Rain level is provided by using an optical infra-red beam sensor. Infra-Red beams bounce off the inner optical surface between transmitters and receivers. Depending on rain drop levels the intensity of the beams change and internal digital signal processing allows a measurement of Rain levels to be made. The sensor increments rain detected in 0.08mm steps (decimal point rounded up, so that 0.08mm = a reading of 0.1mm, 0.16mm = 0.2mm, 0.24mm = 0.3mm, 0.32mm = 0.4mm etc.).

### **2.1.8 Compass (GMX200, GMX500, GMX501 and GMX600)**

MaxiMet contains a 2-axis flux gate compass.

MaxiMet uses the internal compass to electronically sense the horizontal component of the Earth's magnetic field.

Wind direction data is corrected for the orientation of the sensor. The output of the wind direction is relative to magnetic North. The MaxiMet compass is calibrated at Gill Instruments before the unit is delivered.

Prior to installing MaxiMet it is suggested that for best accuracy a declination figure should be entered.

Use of the Compass-Corrected Wind Direction readings allows the unit to be installed such that accurate positioning of the MaxiMet north marker is not required.

“Caution: Gill provide a derived parameter for corrected wind direction and speed information, this derived parameter is based on an algorithm devised by Gill and may not satisfy or meet other known valid standards for correcting a moving object's wind speed and direction heading. Details on the algorithm used are included in the Appendix on pages 9 and 11.

### **2.1.9 Compass Declination**

Declination is the magnetic declination (the angle between Magnetic North and True North) in degrees.

This is a correction factor that is added to the magnetic north heading from the compass.

Map and declination figures in decimal figures can be obtained from:-

<http://www.geosats.com/magdecli.html>

<http://www.ngdc.noaa.gov/geomag/declination.shtml>

### **2.1.10 Solar (GMX301 and GMX501)**

MaxiMet uses a high quality Hukseflux LPO2 second class Solar Radiation/Pyranometer which complies with ISO 9060. This highly accurate instrument uses thermopile technology to measure hemispherical solar radiation from a 180 degree field of view angle.

### **2.1.11 GPS Option (GMX200, GMX500, GMX501 and GMX600)**

MaxiMet uses a highly accurate GPS antenna receiver module including a ceramic GPS patch antenna. The module is capable of receiving signals from up to 48 GPS satellites and transferring them into position and timing information that can be read over a serial port. Small size and high-end GPS functionality are combined with low power consumption.

When GPS Speed and GPS heading are available and GPS Speed transitions are above 5m/s, Corrected Wind Speed shall be computed as the True Wind speed using GPS speed and GPS heading.

### 2.1.12 MaxiMet Output Parameters selectable using MetSet Software

Note: Not in order of output, see para 2.1.2 for applicability and para 6.2.4 for MetSet set up.

#### **NODE**                      **Node Letter.**

MaxiMet identifying Node letter at beginning of the data string.

Result e.g. Q (default).

#### **SPEED**                      **Wind Speed.**

Wind Speed measurement.

Result e.g. 001.05 (Metres/second default).

#### **CSPEED**                      **Corrected Speed.**

Corrected Wind Speed shall be computed as the True Wind Speed (i.e. using GPS Speed, GPS Heading and Compass Heading) when all three of GPS Speed, GPS Heading and Compass Heading are available.

Result e.g. 003.17 (Metres/second default).

Corrected Wind Speed shall not be computed when any one (or more) of GPS Speed, GPS Heading and Compass Heading are unavailable.

The Gill Algorithm for generating Corrected Speed based on Compass heading is as follows:-

1. Convert Magnitude and Direction to UV.
2. Calculate applied wind in UV due to movement from GPS.
3. Calculate Corrected UV as difference between Relative and GPS wind.
4. Convert UV back to Magnitude and Direction.

#### **GSPEED (WMO)**      **Gust Speed.**

Outputs WMO Gust Speed.

Maximum Gust Magnitude shall be computed over a block of m gust magnitudes as follows:

$$rwa\_max\_gust\_mag = \max\{gust\_mag_1, gust\_mag_2 \dots gust\_mag_m\}$$

where

$$m = rwa\_short\_len$$

$$gust\_mag = \sqrt{(u\_avg^2 + v\_avg^2)}$$

$$u\_avg = \frac{\sum_{n=1}^3 u\_vector_n}{3}$$

$$v\_avg = \frac{\sum_{n=1}^3 v\_vector_n}{3}$$

Result e.g. 015.15 (Metres/second default).

**CGSPEED**                      **Corrected Gust Speed.**

GPS corrected Gust Speed.

Result e.g. 011.05 (Metres/second default).

**AVGSPEED (WMO)**                      **Average Speed.**

Outputs the World Meteorological Organisation (WMO) Average Wind Speed reading based on AVG short and AVG long settings (see para 6.2.5).

Result e.g. 001.45 (Metres/second default).

A short term average magnitude shall be computed every *rwa\_short\_len* samples as follows:

$$mag\_st = \sqrt{(u\_st^2 + v\_st^2)}$$

where

$$u\_st = \frac{\sum_{n=1}^N u\_vector_n}{N}$$

$$v\_st = \frac{\sum_{n=1}^N v\_vector_n}{N}$$

*u\_vector\_n* = *n*th calibrated *u* – vector generated at "*P*"-rate

*v\_vector\_n* = *n*th calibrated *v* – vector generated at "*P*"-rate

*N* = *rwa\_short\_len*

A long term average direction shall be computed every *rwa\_long\_len* samples as follows:

$$rwa\_direction = \arctan\left(\frac{u\_lt}{v\_lt}\right)$$

where

$$u\_lt = \frac{\sum_{n=1}^M u\_st_n}{M}$$

$$v\_lt = \frac{\sum_{n=1}^M v\_st_n}{M}$$

*u\_st\_n* = *n*th short – term *u* – vector average defined above

*v\_st\_n* = *n*th short – term *v* – vector average defined above

**AVGCSPEED (WMO)**                      **Average Corrected Speed.**

Outputs the World Meteorological Organisation (WMO) Average Wind Speed reading based on AVG short and AVG long settings (see para 6.2.5).

Result e.g. 001.45 (Metres/second default).

**DIR Direction.**

Wind Direction relative to the MaxiMet North Marker.

Result e.g. 132 (degrees).

**CDIR Corrected Direction.**

Corrected Wind Direction shall be computed as the Apparent Wind Direction (i.e.: using Compass Heading) when Compass Heading is available but any one (or more) of GPS Speed and GPS Heading are unavailable.

Corrected Wind Direction shall be computed as the True Wind Direction (i.e.: using GPS Speed, GPS Heading and Compass Heading) when all three of GPS Speed, GPS Heading and Compass Heading are available.

Result e.g. 116 (degrees).

Corrected Wind Direction shall not be computed when Compass Heading is unavailable.

The Gill Algorithm for generating Corrected Direction based on Compass heading is as follows:-

1. Convert Magnitude and Direction to UV.
2. Calculate applied wind in UV due to movement from GPS.
3. Calculate Corrected UV as difference between Relative and GPS wind.
4. Convert UV back to Magnitude and Direction.

**GDIR (WMO) Gust Direction.**

Outputs WMO Gust Direction.

Maximum Gust Direction shall be computed over a block of m vector averages as follows:

$$rwa\_max\_gust\_dir = \arctan\left(\frac{u\_avg_k}{v\_avg_k}\right)$$

where

*k = index of gust\_mag selected for rwa\_max\_gust\_mag defined above*

*u\_avg\_k = k<sup>th</sup> u – vector average defined above*

*v\_avg\_k = k<sup>th</sup> v – vector average defined above*

Result e.g. 123 (degrees).

**CGDIR Corrected Gust Direction.**

GPS corrected Gust Direction.

Result e.g. 135 (degrees).

**AVGDIR (WMO) Average Direction.**

Outputs WMO Average Direction Wind reading based on AVG short and AVG long settings (see para 6.2.5).

Result e.g. 145 (degrees).

A short term average direction shall be computed every  $rwa\_short\_len$  samples as follows:

$$dir\_st = \arctan\left(\frac{u\_st}{v\_st}\right)$$

where

$u\_st$  = short – term average  $u$  – vector defined above

$v\_st$  = short – term average  $v$  – vector defined above

A long term average direction shall be computed every  $rwa\_long\_len$  samples as follows:

$$rwa\_direction = \arctan\left(\frac{u\_lt}{v\_lt}\right)$$

where

$$u\_lt = \frac{\sum_{n=1}^M u\_st_n}{M}$$

$$v\_lt = \frac{\sum_{n=1}^M v\_st_n}{M}$$

$u\_st_n$  =  $n$ th short – term  $u$  – vector average defined above

$v\_st_n$  =  $n$ th short – term  $v$  – vector average defined above

### **AVGCDIR (WMO) Average Corrected Direction.**

Outputs WMO average Compass Corrected Direction wind reading based on AVG short and AVG long settings (see para 6.2.5).

Result e.g. 131 (degrees).

### **PRESS Pressure.**

Outputs the MaxiMet Pressure reading

Result e.g. 1021.3 (hecto-pascals default).

### **PASL Pressure at Sea Level.**

Outputs Barometric Pressure at Sea Level if HASL figure set (see page 13 and page 51).

$$P = Pb(Tb / (Tb + (Lb * (-h)))) ^ ((g0 * M)/(R * Lb))$$

where:

$P$  = adjusted pressure

$Pb$  = pressure (pascals) - as measured by the pressure sensor

$Tb$  = temperature (K)

$Lb$  = standard temperature lapse rate (K/m) in ISA. For the Troposphere this is assumed to be - 0.0065 Kelvin/metre.

$h$  = height (meters) = sensor's height above (or below) sea level, i.e. 'Height Above Sea Level' plus 'Height Above Station'

$R$  = universal gas constant for air: 8.31432 N•m/(mol•K)

$g0$  = gravitational acceleration (9.80665 m/s<sup>2</sup>)

$M$  = molar mass of Earth's air (0.0289644 kg/mol)

Result e.g. 1015.7 (hecto-pascals default).

## PSTN Pressure at Station.

Outputs Barometric Pressure at Station (which can be positioned anywhere) if HASTN figure set (see below and page 51).

Pressure at station shall be computed as:

$$P = P_b \left( \frac{T_b}{T_b + (L_b \cdot (-h))} \right)^{\left( \frac{g_0 \cdot M}{R \cdot L_b} \right)}$$

where:

P = adjusted pressure

P<sub>b</sub> = pressure (pascals) - as measured by the pressure sensor

T<sub>b</sub> = temperature (K)

L<sub>b</sub> = standard temperature lapse rate (K/m) in ISA. For the Troposphere this is assumed to be - 0.0065 Kelvin/metre.

h = height (meters) = 'Height Above Station', i.e. the difference between the sensor height above (or below) local ground level.

R = universal gas constant for air: 8.31432 N•m/(mol•K)

g<sub>0</sub> = gravitational acceleration (9.80665 m/s<sup>2</sup>)

M = molar mass of Earth's air (0.0289644 kg/mol)

Result e.g. 1001.2 (hecto pascals default).

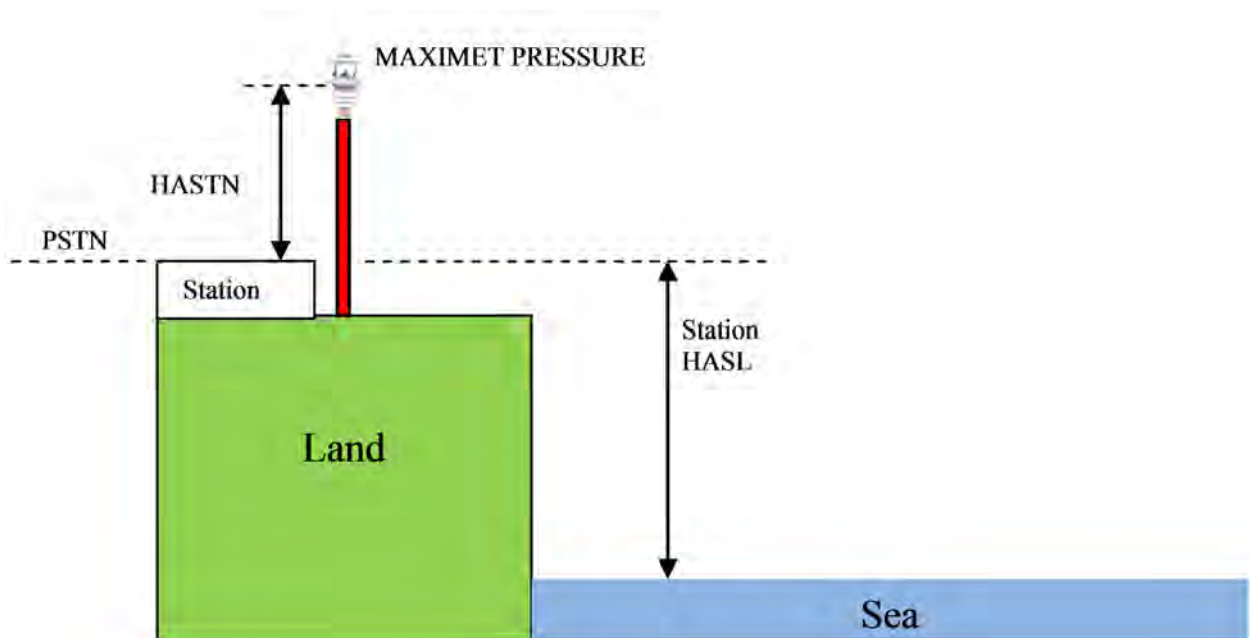

## RH Relative Humidity.

Outputs the measured Relative Humidity reading in %.

Result e.g. 45.1 (%).

## AH Absolute Humidity.

The humidity of the atmosphere, usually expressed as the number of grams of water contained in 1 cubic metre of air.

(Note Relative Humidity also output, expressed as a percent, measures the current absolute humidity relative to the maximum for that temperature).

Absolute humidity shall be computed as:-  $H = C \times P_w/T$ .

Where:-

H = absolute humidity

C = Constant 2.16679 gK/J

P<sub>w</sub> = Vapour pressure in Pa

T = Temperature in K

Result e.g. 08.14 g/m<sup>3</sup>.

**TEMP                      Temperature.**

Outputs MaxiMet Temperature sensor readings.  
e.g. 022.0 (degrees C default).

**DEWPOINT              Dewpoint.**

Output calculated Dewpoint from Temperature and Humidity readings.

$$Td = Tn / (Y-1)$$

Where

Td = Dewpoint temperature

Y =  $m/\log_{10}(Pw/A)$

Tn=Triple point temperature (in K)

Pw = Pws . RH / 100 (hPa)

Pws = water vapour saturation pressure (hPa)

Result e.g. 23.1 (%).

**PRECIPT                Precipitation Total.**

Outputs Precipitation (Rain) Total reading, is an accumulated rain reading output updated once per second (with default output rate setting at 1Hz).

Is set to zero on MaxiMet power up.

Is set to zero when the clock reads 23:59:59 to 00 (midnight) and is the default setting.

For continuous measurement turn off Auto-reset of Total Precipitation using MetSet.

Result e.g. 00000.4 (millimetres default).

**PRECIPI                Precipitation Intensity.**

Outputs Precipitation (Rain) Intensity. It is the sum of the last sixty lots of 1 minute accumulated Rain data. A new sum measurement is generated every minute.

It will be set to zero on MaxiMet power up.

Result e.g. 000.2 (millimetres default).

**PRECIPS                Precipitation Status.**

Outputs Precipitation (Rain) Status as N or Y (No or Yes).

Changes N to Y when total precipitation is incremented.

Changes Y to N when total precipitation has not incremented in the last 60 seconds.

Result e.g. N (or Y).

**SOLARRAD              Solar Radiation figure.**

Measure solar radiation over the range 0-1600 in watts per metre squared.

Result e.g. 0243.

**SOLARHOURS          Sunshine Hours.**

Sunshine hours are computed as the period of time, in hours, within a 24 hour calendar day (i.e.: accumulated during the present day) that the measured irradiance exceeds 120 W/m<sup>2</sup>.

Sunshine hours shall be displayed with 2 integral digits and 2 decimal places.

Result e.g. 00.00 hours.

**COMPASSH              Compass Heading.**

North direction read out from the MaxiMet compass.

Result e.g. 139 (degrees).

**GPSHEADING      GPS Enabled Heading.**

GPS Heading shall be displayed with 3 integral digits.

Result e.g. 064 (degrees).

**GPSSPEED      GPS Speed over Ground.**

Velocity at which the MaxiMet unit with GPS is travelling over ground.

E.g. +000.10 (metres/second (default)).

In feet/minute setting then a reading might be 00020 (no decimal places).

**GPSLOCATION      GPS Latitude, Longitude and Height.**

Result e.g.      +50.762956:-001.539948:+4.90.

Where            +50.762956 is Latitude ( $\pm 90$  Degrees North/South), positive latitude equals North.

Where            -001.539948 is Longitude ( $\pm 180$  Degrees East/West), negative longitude equals West.

Where            +4.90 is height. Using GPS means that regardless of whether a station is located on a mountain or on the coastline of a country it is possible to compare pressure readings without any further calculations as the GPS information gives the height information needed to calculate the difference in elevation to sea level and then it is possible to correct the reading for it.

**GPSSTATUS      Location Fix and Number of Satellites.**

Result e.g. 010B.

Where            0 is padding.

                     1 is GPS SPS mode fix valid (0 is fix not available).

                     0B is a hexadecimal representation of the number of satellites acquired, 11 satellites found. 0A would be 10 satellites etc.

**TIME (and Date)      MaxiMet Date and Time (can be updated by GPS Option).**

Time can be set manually by the user or updated by the GPS Module (if fitted).

GPS time can be automatically updated every hour (GPS default setting).

By default time will be UTC.

Result e.g. 2015-06-04T10:01:36.8.

**VOLT      Supply Voltage.**

DC Supply voltage measured at the MaxiMet.

Result e.g. +10.5.

**STATUS      Status of MaxiMet Sensors.**

Outputs the MaxiMet Sensors Status Code.

Result e.g. 0000 (see para 8.3).

**WINDSTAT      Status of Wind Sensor in detail.**

Outputs Status codes relating to Wind Sensor Data.

Result e.g. 0000 (see para 8.3).

## 2.2. GMX Sensor Default ASCII Output Summary

### 2.2.1 GMX100 Default Data String

Non GPS.

Node, Total Precipitation, Precipitation Intensity, Date and Time, Supply Voltage, Status, Checksum

⌋ Q, 00000.2,000.2,2015-06-05T10:19:30.8,+05.1,0000,⌋ 36

### 2.2.2 GMX200 Default Data String

Non GPS Option

Node, Relative Wind Direction, Relative Wind Speed, Corrected Wind Direction, Date and Time, Supply Voltage, Status, Checksum.

⌋ Q,127,000.03,000,2000-01-01T00:40:50.2,+10.5,0000,⌋ 21

GPS Option

Node, Relative Wind Direction, Relative Wind Speed, Corrected Wind Direction, Corrected Wind Speed, GPS location Date and Time, Supply Voltage, Status, Checksum.

⌋ Q,310,000.04,033,000.59,+50.762988:-001.539893:-0.80,2000-01-01T00:40:50.2,+10.5,0000,⌋ 21

### 2.2.3 GMX300 Default Data String

Non GPS.

Node, Pressure, Relative Humidity, Temperature, Dewpoint, Date and Time, Supply Voltage, Status, Checksum.

⌋ Q, 1015.3,041,+022.0,+008.5,2015-06-05T10:19:30.8,+05.1,0000,⌋ 36

### 2.2.4 GMX301 Default Data String

Node, Pressure, Relative Humidity, Temperature, Dewpoint, Solar Radiation, Date and Time, Supply Voltage, Status, Checksum.

e.g. ⌋ Q,1018.5,037,+023.0,+007.8,0000,2014-05-24T06:21:01.0,+10.3,0000,⌋ 3C

### 2.2.5 GMX400 Default Data String

Non GPS.

Node, Pressure, Relative Humidity, Total Precipitation, Precipitation Intensity, Date and Time, Supply Voltage, Status, Checksum.

⌋ Q,1015.3,041,+022.0,+008.5,00000.2,000.2,2015-06-05T10:19:30.8,+05.1,0000,⌋ 36

## 2.2.6 GMX500 Default Data String

### Non GPS

Node, Relative Wind Direction, Relative Wind Speed, Corrected Wind Direction, Pressure, Relative Humidity, Temperature, Dewpoint, Date and Time, Supply Voltage, Status, Checksum.

⌈ Q,329,000.01,340,1032.1,040,+020.6,+006.7,2015-06-09T09:24:19.9,+05.1,0000,⌋ 10

### GPS

Node, Relative Wind Direction, Relative Wind Speed, Corrected Wind Direction, Corrected Speed, Pressure, Relative Humidity, Temperature, Dewpoint, GPS Location, Date and Time, Supply Voltage, Status, Checksum.

⌈ Q,310,000.04,033,000.59,1032.1,040,+020.6,+006.7,+50.762988:-001.539893:-0.80,2015-06-09T09:24:34.9,+05.1,0000,⌋ 3D

## 2.2.7 GMX501 Default Data String

### Non GPS

Node, Relative Wind Direction, Relative Wind Speed, Corrected Wind Direction, Pressure, Relative Humidity, Temperature, Dewpoint, Solar Radiation, Date and Time, Supply Voltage, Status, Checksum.

⌈ Q,329,000.01,340,1032.1,040,+020.6,+006.7,0001,2015-06-09T09:24:19.9,+05.1,0000,⌋ 10

### GPS

Node, Relative Wind Direction, Relative Wind Speed, Corrected Wind Direction, Corrected Wind Speed, Pressure, Relative Humidity, Temperature, Dewpoint, Solar Radiation, GPS Location, Date and Time, Supply Voltage, Status, Checksum.

⌈ Q,310,000.04,033,000.59,1032.1,040,+020.6,+006.7,0001,+50.762988:-001.539893:-0.80,2015-06-09T09:24:34.9,+05.1,0004,⌋ 3D

## 2.2.8 GMX600 Default Data String

### Non GPS

Node, Relative Wind Direction, Relative Wind Speed, Corrected Wind Direction, Pressure, Relative Humidity, Temperature, Dewpoint, Total Precipitation, Precipitation Intensity, Date and Time, Supply Voltage, Status, Checksum.

⌈ Q,344,000.05,096,1018.5,037,+023.0,+007.8,00000.0,000.0,2014-05-24T06:21:01.0,+10.3,0002,⌋ 3C

### GPS

Node, Relative Wind Direction, Relative Wind Speed, Corrected Wind Direction, Corrected Wind Speed, Pressure, Relative Humidity, Temperature, Dewpoint, Total Precipitation, Precipitation Intensity, GPS Location, Date and Time, Supply Voltage, Status, Checksum.

⌈ Q,344,000.05,096,000.59,1018.5,037,+023.0,+007.8,00000.0,000.0,+50.762988:-001.539893:-0.80,2014-05-24T06:21:01.0,+10.3,0002,⌋ 3C

### 3. TECHNICAL SPECIFICATION

Wind Measurement	
Parameters	Parameters
Units of Measurement	Units of Measurement
Wind Speed	
Range	0.01 to 60m/s
Accuracy	± 3% 0.01m/s to 40m/s ± 5% above 40 and up to 60m/s
Resolution	0.01m/s
Threshold	0.01m/s
Wind Direction	
Range	0-359 Degrees – No dead band
Accuracy	± 3° 0.01m/s to 40m/s ± 5° above 40 and up to 60m/s
Resolution	1°

Compass	
Range	0-359 degrees
Resolution Compass Heading	1°
Units of Measure	Degrees
Accuracy	± 3°

Air Temperature	
Range	-40°C to +70°C
Accuracy	±0.3°C @ 20°C
Resolution	0.1°C
Units of Measure	°C or °F or °K

Relative Humidity	
Range	0-100%
Accuracy	±2% @ 20°C (10% to 90% Relative Humidity)
Resolution	1%
Units of Measure	% RH

Dew Point	
Range	-40°C to +70°C
Resolution	0.1°C
Accuracy	±0.3°C @ 25°C
Units of Measure	°C or °F or K

Barometric Pressure	
Range	300 to 1100hPa
Accuracy	±0.5hPa @ 25°C.
Resolution	0.1hPa
Units of Measure	hPa, mbar, mmHg, InHg

<b>Rain GMX100, GMX400 and GMX 600</b>	
Precipitation Intensity	0 to 150mm per hour.
Resolution	0.08mm rain/tip (start measurement level 0.1mm)
Units of Measure	milli-metres, inches

<b>Solar</b>	
Range	300 to 3000nm
Intensity Range	0 to 1600W/m <sup>2</sup>
Accuracy	±2%
Resolution	1W/m <sup>2</sup>
Units of Measure	Watts per Metre Squared

<b>GPS</b>	
Horizontal Position accuracy	Less than 2.5M Circular Error Probability (Selective Availability Off)
Time to fix	Less than 45 seconds from unit power up when stationary
Channels	48
Accuracy	Longitude and Latitude report to 6 decimal places
GPS Time Update	Allow 1 hour upon switch on for GPS time update

<b>Real Time Clock</b>	
Format Date and Time	YYYY-MM-DDThh:mm:ss.s, e.g. : 2014-12-25-T22:34:56.1,
Updating	Manual Setting or via GPS option
Power Loss Accuracy	±10 seconds for at least 24 hours after power removed from MaxiMet.
Clock back up Period	24 hours.

<b>Outputs</b>	
Digital Outputs	RS232, RS422, *RS485 (*2 wire point to point) or SDI-12. (RS232 point to point and RS485 2 wire networkable – MODBUS RTU/ASCII)
Baud Rates	1200 (SDI-12), 4800-57600 (ASCII RS232, RS422, *RS485) 9600-19200 (MODBUS RTU/ASCII)
Protocols	ASCII, SDI-12 V1.3, NMEA 0183 or MODBUS RTU/ASCII
Data Output	1 reading per second (1 Hz), 1 reading per minute, 1 reading per hour or Polled Mode
MaxiMet Status	Status codes provided within the data message string

<b>Power Supply</b>	
Input voltage (RS232, RS422, RS485)	5v to 30v dc
Average Current at 12v dc with power saving mode disabled (default).	GMX100 - 42mA GMX200 - 22mA. GMX300 - 5mA GMX301 – 5.5mA. GMX400 - 45mA GMX500 - 24mA. GMX501 - 24mA. GMX600 - 64mA. For GPS enabled units allow for an additional 10mA.

Average Current at 12v dc in Power Saving Mode and poll for a reading once per hour.	GMX100 - 0.7mA GMX200 – 0.7mA. GMX300 - 0.7mA GMX301 – 0.7mA GMX400 - 0.7mA GMX500 – 0.7mA GMX501 – 0.7mA GMX600 – 0.7mA For GPS enabled units allow for an additional 6mA.
--	---

<b>Environmental</b>	
Protection Class	IP66
EMC	BS EN 61326 FCC CFR47 Parts 15.109
Operating Temperature	-40°C to +70°C
Storage Temperature	-40°C to +80°C
Humidity	0-100%
RoHS Compliant	Yes

<b>Mechanical</b>	
External Construction	Polycarbonate.
Fittings	Bolt fittings supplied for securing the unit to a vertical pipe of diameter 44.45mm.
Overall Dimensions	
GMX100	142mm x 142mm x 142mm
GMX200	169.5mm x 142mm x 142mm
GMX300	155mm x 142mm x 142mm
GMX301	198mm x 142mm x 142mm
GMX400	195mm x 142mm x 142mm
GMX500	222mm x 142mm x 142mm
GMX501	264mm x 142mm x 142mm
GMX600	261mm x 142mm x 142mm
Weight	
GMX100	0.4kg
GMX200	0.5kg
GMX300	0.48kg
GMX301	0.6kg
GMX400	0.55kg
GMX500	0.7kg
GMX501	0.8kg
GMX600	0.8kg

<b>Software</b>	
MetSet Configuration	Free Software on the supplied CD providing the means of configuration of the MaxiMet.
MetView	Free Software on the supplied CD providing the means of viewing MaxiMet data graphically and logging data.

## 4. PRE-INSTALLATION

### 4.1. Equipment supplied

- MaxiMet.
- and Installation kit (1405-PK-069) comprising of a 9 way connector kit and 3 off M5 bolts and washers to bolt the unit to a mounting pole.
- and MaxiMet User Manual and MetSet Software on a CD in the MaxiMet box (this manual).
- and Product Test Report.

#### 4.1.2 Optional Extras:

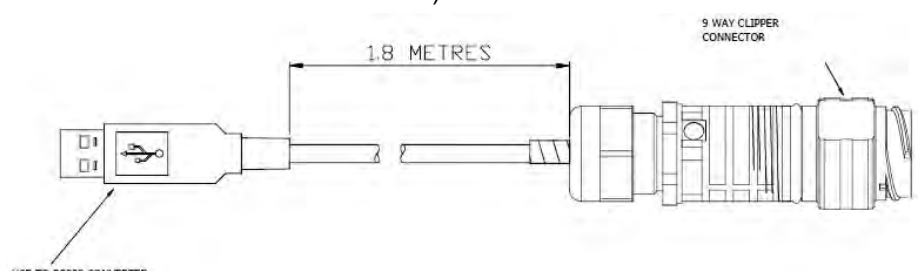
Item	Part Number
Cable 3 Pair twisted and Shielded wires, 24awg, per metre.	026-02660
Cable 4 Pair twisted and Shielded wires, 24awg, per metre.	026-03156
Cable 15 metres (4 pair twisted and shielded 24 awg – connector pins attached to one end and stripped wires the other).	1405-10-080
9 way connector and 3 mounting bolts (1 supplied with the unit)	1405-PK-069
0.5 Metre x 50mm Aluminium Support Tube tapped for MaxiMet Mounting bolts	1405-30-056
MaxiMet Mounting Bracket	1771-PK-115
MaxiMet 1.8 Metre RS232 to USB converter including 5v dc power and communication configuration cable (9 way MaxiMet connector fitted one end and USB connector at the other end). 	1957-10-065

### 4.2. Connector and Cable Assembly.

The MaxiMet is supplied with a mating 9 way connector.

Open the pack of connector parts supplied (Gill Part 1405-PK-069).

Part Name	Souriau Clipper Part Number.
Connector 9 way	CLF1201
Backshell	CL101021
Solder bucket contacts (9 required)	CM10SS10MQ

#### Arrange Backshell Parts.

Trim back the screened cable outer and screen sleeves 40mm.

Trim back the screen drain wires flush with the outer sleeve.

Strip back the connection wires by 5mm and tin solder.

Solder the contact pins to the wires (please note that the connector supplies the correct strain relief for cables with an outside diameter of 6-12mm).

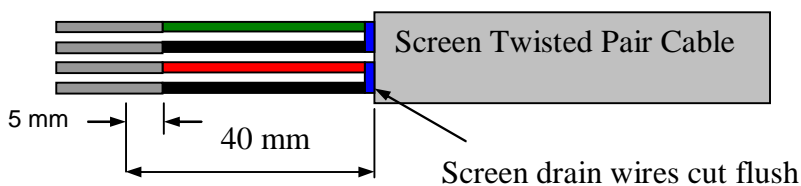

Put the parts on the cable in the order as shown below.



Whilst squeezing the red retainer in the direction of ARROWS A, pull in the direction of ARROW B.



Your connector should now resemble the connector in the picture below.



Insert each contact pin until you feel a slight click. If you have inserted the contact into the incorrect hole it can be removed at this point by simply pulling it out. Please note there will be some resistance.



Rear View of Connector

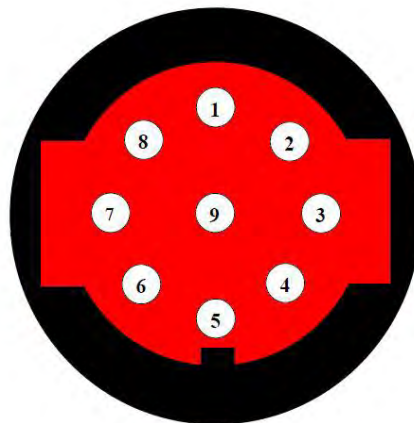

Continue to insert all of the contacts you require. Once all of the contacts are inserted push the red retainer into place. NB. The retainer can only be pushed back into place if the contacts are fully engaged.



Fit the connector to the MaxiMet so that you can finish assembling the connector.



Screw the back shell onto the connector until it is fully in place. Please note that the final rotations can be slightly stiff.



Now screw the next part of the connector into place.



Now screw the cable-clamping nut into place.



The connector can now be removed from the MaxiMet.

**NOTE: To disassemble the connector, reverse this procedure.**

## 4.3. Cabling

All MaxiMets have five output communication connection options:

USB (using the 1.8m MaxiMet RS232 to USB cable, Part No. 1957-10-065).

RS232

RS422

RS485 (Gill ASCII, two wire point to point) Modbus two wire networkable.

SDI-12

Note: It is important that the cable is appropriate for the chosen communication network. The following sections describe the recommended types and maximum lengths of cable in each case.

### 4.3.1 Cable type

#### Digital Communications

**Wire type:** 24AWG

**Wire size:** 7x32 AWG.

**Cable outer diameter:** 6-12mm (to match the connector gland).

For RS422/485 operation the cable should have twisted pairs with drain wire, screened with aluminised tape, with an overall PVC sheath. Typical wire size 7/0.2mm (24 AWG).

The following table shows an example manufacturers' reference; other manufacturers' equivalents can be used.

#### Recommended cable types

Application	No. of Pairs	24 AWG Gill Ref.	24 AWG Belden Ref.	24 AWG Batt Electronics Ref.
SDI-12	2	-	9729	-
Digital RS232 or RS485 2 wire	3	026-02660	9730	91030
Digital RS422/RS485 4 wire	4	026-03156	9728	91199

### 4.3.2 Cable length

The maximum cable length is dependent on the chosen communication method.

The following table shows the maximum cable lengths for the supported communication protocols at the given baud rates, using the recommended cable. If any problems of data corruption etc. are experienced, then a slower baud rate should be used. Alternatively, a higher specification cable can be tried.

#### Suggested maximum cable lengths for supported communication networks

Communication format	Baud rate	Max. cable length
RS232	19200	6.5M
RS422/RS485	19200	1000M
SDI-12	1200	90M

## 4.4. Connections

Any cable wires not used should be isolated and grounded at the terminating equipment/user end. Digital OV should be used in conjunction with RS422 TX/RX lines in order to improve noise immunity.

### 4.4.1 View of the MaxiMet connector

Looking down at the Cable side.

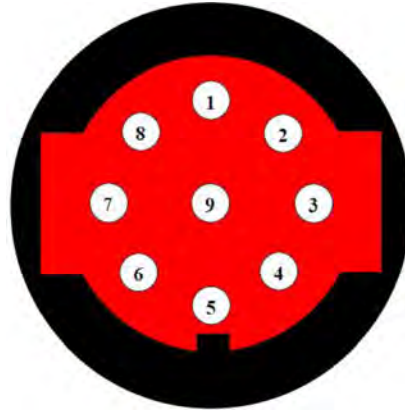

### 4.4.2 9 way connector and cable connections

9 Way Connector Number	Signal Designation
1	Signal Ground
2	Supply +ve
3	Supply -ve
4	RS422/485 TXD+
5	RS232 TXD, RS422/RS485 TXD-
6	RS422/RS485 RXD+
7	RS232 RXD, RS422/RS485 RXD-
8	<b>Comms Select – Only.</b> <b>Applicable if MaxiMet COMMS Interface Setting set for EXT</b> using MetSet. If MaxiMet is set for EXT Comms then:- For RS232 connect Pin 8 to Pin 2 +ve. For RS422 leave Pin 8 open circuit or connect to Pin 3 -ve.
9	SDI-12 Data

## 4.5. Power supplies

### 4.5.1 MaxiMet units

Supply Voltage: 5v to 30v DC.

Average Current at 12v dc with power saving mode disabled (add 10mA for GPS versions):-

GMX100	42mA.
GMX200	22mA.
GMX300	5mA.
GMX301	5.5mA.
GMX400	45mA.
GMX500	24mA.
GMX501	24mA
GMX600	64mA.

MaxiMet has reverse polarity protection.

## 4.6. Connecting to a PC using RS232 (Default setting)

1. MaxiMet default factory comms setting is RS232.
2. The recommended cable length for reliable operation is limited to 6.5m (20ft).
3. For longer cable runs, we recommend use of RS422 output.
4. As an alternative method of using MaxiMet with RS232 comms change the COMMS setting from RS232 to EXT and connect Pin 8 to the +ve supply connection (dotted line connection).
5. If EXT is selected and Pin 8 is left open circuit then note that RS422 comms will be set.

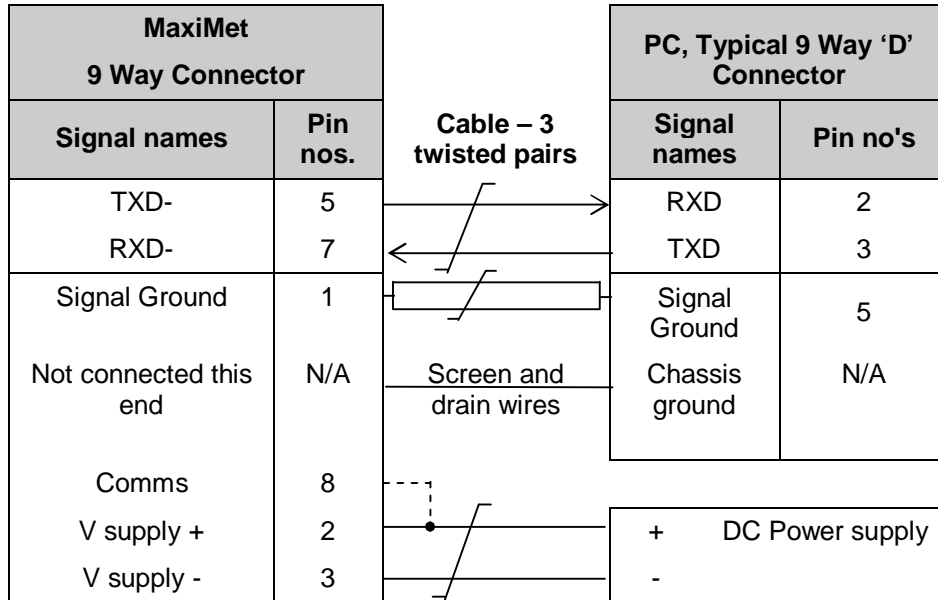

## 4.7. Connecting to a PC using RS422 (Not a Default Setting)

1. MaxiMet default factory comms setting is RS232.
2. To use the MaxiMet with RS422 comms use MetSet to change the COMMS Interface setting to RS422.
3. Alternatively use MetSet to change the COMMS Interface setting to EXT and leave connector Pin 8 open circuit.
4. If EXT is selected and Pin 8 connected to Pin 2 supply positive then COMMS will change to RS232.

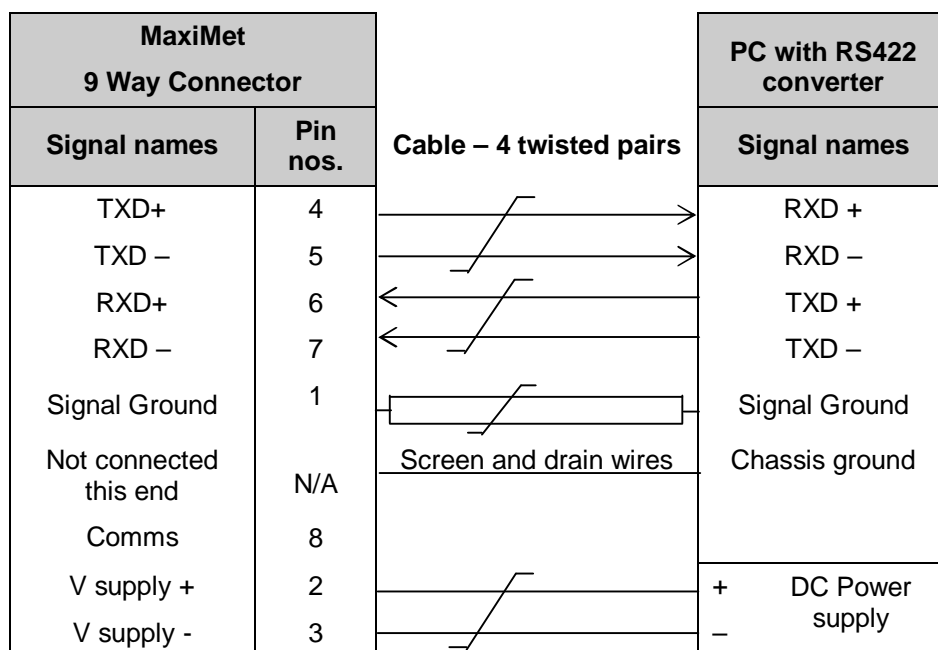

### 4.8. Using RS485 (not a default setting).

1. **MaxiMet default factory comms setting is RS232.**
2. To use the MaxiMet with RS485 2 wire point to point communication use MetSet to **change the COMMS Interface setting to RS485P 2W.**
3. For Gill ASCII two wire mode use MetSet to **change the Message setting from CONT (Continuous) to POLL**, the node address letter may be changed if required.
4. For RS485 two wire fully networkable Modbus Mode **leave the Message setting in CONT (Continuous).**
5. Leave connector Pin 8 open circuit.

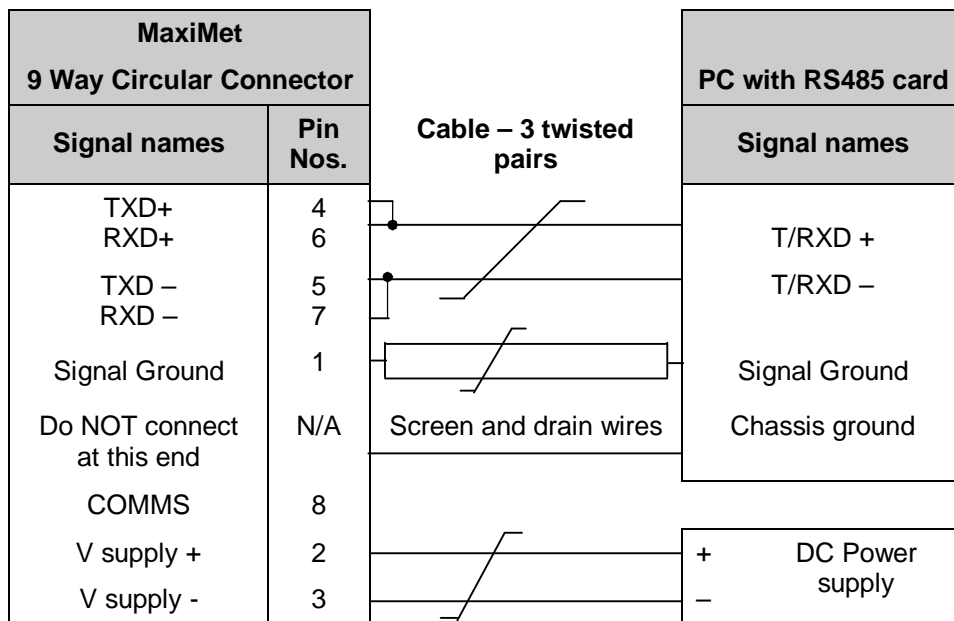

### 4.9. Using SDI-12 (2 wire network) not a default setting.

1. **MaxiMet default factory comms setting is RS232.**
2. Use MetSet to change the COMMS Interface setting to SDI 12.

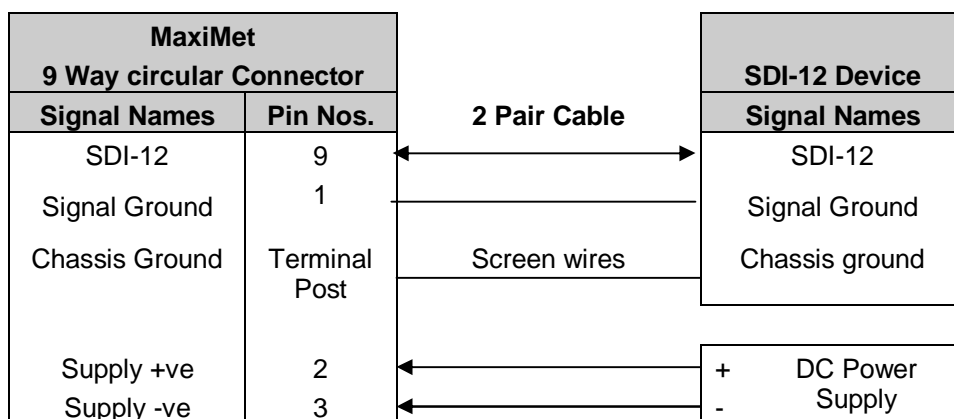

## 4.10. Set up requirements

### 4.10.1 Host System:

Note: The default delivery output communication setting of MaxiMet output is RS232 with the COMMS Interface setting set for RS232.

Use an RS232 to USB converter e.g. Gill part 1957-10-065, 1.8M configuration cable fitted with 9 way MaxiMet connector and with integral 5v USB connector power for MaxiMet (see Para 4.1.2). If an install driver is required for this cable it can be obtained from the supplied CD or downloaded from:-

<http://www.ftdichip.com/FTDrivers.htm>

Or

Use an RS232 to USB adaptor or equivalent for example EasySynch part ES-U-1001-A (if not using Gill part 1957-10-065) or connect directly to an RS232 COM port.

Use a PC running Windows software up to and including Windows 10 and with an internal or external interface compatible with the output from the MaxiMet.

Use a Power Supply, 5V to 30Vdc at 200mA if not using the Gill Instruments Configuration cable.

Use 3 pair cable e.g. Belden 9503 (if not using Gill Part 1723-10-051), length as required if not using the Gill Instruments Configuration cable.

### 4.10.2 Software:

Gill MetSet Software used as a configuration Tool (supplied on MaxiMet CD), will run on PC's with up to and including Windows 10 and can be downloaded free from:-

<http://www.gillinstruments.com/main/software.html>

### 4.10.3 Bench system test

The CD supplied in the MaxiMet box contains a copy of the manual and relevant software to check and set up the MaxiMet unit.

Prior to physically mounting the MaxiMet in its final location, we strongly recommend that a bench system test be carried out to confirm the system is configured correctly, is fully functional and electrically compatible with the selected host system and cabling (preferably utilising the final cable length). The required data format, units, output rate, and other options should also all be configured at this stage.

Connect the MaxiMet to a PC wired as per RS232 connections in Para 4.6.

Alternatively use a Gill configuration cable part 1957-10-065 with a 9 way connector fitted on one end and USB converter at the other end if required to simplify set up between MaxiMet and a PC.

Open Gill MetSet software provided to read, check settings or change settings as per para 6.2.

Use MetSet to View the data string and confirm that the Status field reads 0000.

## 4.11. Packaging

Whilst the MaxiMet is being moved to its installation site, the unit should be kept in its packaging. Retain the packaging for test bench and use if the unit has to be moved or returned to Gill Instruments.

## 5. INSTALLATION

### 5.1. General Installation Guidelines

#### 5.1.1 Interference

As with any sophisticated electronics, good engineering practice should be followed to ensure correct operation.

Always check the installation to ensure the MaxiMet is not affected by other equipment operating locally, which may not conform to current standards, e.g. radio/radar transmitters, boat engines, generators etc.

Do NOT mount the MaxiMet in close proximity of high-powered radar or radio transmitters. A site survey may be required if there is any doubt about the strength of external electrical noise.

Guidelines –

Avoid mounting in the plane of any radar scanner – a vertical separation of at least 2m should be achieved.

Radio transmitting antennas, the following minimum separations (all round) are suggested

VHF IMM – 1m

MF/HF – 5m

Satcom – 5m (avoid likely lines of sight)

Ensure the product is correctly earthed in accordance with this manual.

Use cables recommended by Gill, keeping the length below the maximum allowed. Where the cables are cut and re-connected (junction boxes, plugs and sockets) the cable screen integrity must be maintained, to prevent the EMC performance being compromised.

Earth loops should not be created – earth the system in accordance with wiring diagrams.

Ensure the power supply operates to the MaxiMet specification at all times.

#### 5.1.2 Wind

Avoid turbulence caused by surrounding structures that will affect the accuracy of the MaxiMet such as trees, masts and buildings.

The World Meteorological Organisation makes the following recommendation:

The standard exposure of wind instruments over level open terrain is 10m above the ground. Open terrain is defined as an area where the distance between the sensor and any obstruction is at least 10 times the height of the obstruction.

If mounting on a building then theoretically the sensor should be mounted at a height of 1.5 times the height of the building.

If the sensor is to be mounted on a mast boom, part way up a tower or mast, then the boom should be at least twice as long as the minimum diameter or diagonal of the tower. The boom should be positioned on the prevailing wind side of the tower.

It is important to ensure that the MaxiMet is mounted in a position clear of any structure, which may obstruct the airflow or induce turbulence.

Mount MaxiMet so as to have a clear view of prevailing winds.

### **5.1.3 Compass**

MaxiMet should be mounted horizontally and vertically as level as possible.

It is not possible to calibrate for changing magnetic anomalies. Thus, for greatest accuracy, keep the MaxiMet away from sources of local magnetic distortion that will change with time; such as electrical equipment that will be turned on and off, or ferrous bodies that will move. Make sure that MaxiMet is not mounted close to areas that may be see large sources of local magnetic fields.

Electric motors usually generate magnetic fields that are much stronger than the earth's field. It is recommended that MaxiMet be moved as far away from the motors as possible.

As a guide ensure that MaxiMet is mounted at least 1 metre away from Ferrous objects to prevent them influencing the compass reading.

A declination correction factor can be added to the magnetic north heading from the compass.

Map and declination figures in decimal figures can be obtained from:-

<http://www.geosats.com/magdecli.html>

<http://www.ngdc.noaa.gov/geomag/declination.shtml>

### **5.1.4 GPS**

MaxiMet should be mounted horizontally and vertically as level as possible.

A clear view of the sky is best for an optimal satellite lock. Tree canopy, surrounding hills/mountains, tall buildings and any mounting structure/mast that obscures the view overhead or of the horizon can impede reception.

Signal multipath errors can occur if the GPS signal is reflected off objects such as tall buildings or large rock surfaces before it reaches the receiver. This increases the travel time of the signal, thereby causing errors.

Number of satellites visible- The more satellites a GPS receiver can see, the better the accuracy. Buildings, terrain, electronic interference, or sometimes even dense foliage can block signal reception, causing position errors or possibly no position reading at all. GPS units typically will not work indoors or underground.

### **5.1.5 Solar**

MaxiMet should be mounted horizontally and vertically as level as possible during installation for optimal readings.

A clear view of the sky is best for an optimal solar measurement. Mounting obstructions, tree canopy, hills, mountains and tall buildings that obscure the view overhead or of the horizon can impede solar readings.

### **5.1.6 Rain**

Integrated Solid State Rain Sensor.

MaxiMet with an integrated rain sensor should ideally be mounted horizontally and vertically as level as possible for optimal readings.

A clear view of the sky is best for optimal rain measurements. Adjacent mounting obstructions or tall landscape features could impede rain readings.

### 5.1.7 General Alignment

The MaxiMet anemometer should be set to point North (or to another known reference direction), using the North Pointers, which are identified on the instrument figure on page 7.

If the MaxiMet Compass output is enabled by using MetSet (Report Page and COMPASSH setting) then a direct magnetic north compass reading can be used to set MaxiMet north markers to north.

Otherwise MaxiMet need not be aligned precisely if the compass Corrected Direction (CDIR) readings are to be used.

### 5.1.8 Mounting Tube e.g. Gill Part 1405-30-056.

A tube 1.75 inches (44.45mm) Outside Diameter x 3mm wall thickness is recommended (see figures on the next pages). **Note it is important that the correct diameter tube is used to prevent damage to the MaxiMet lower moulding when tightening the screws.**

The support tube requires three 3 equally spaced holes, tapped M5, 7.5mm from the top of the tube. Pass the cable (fitted with the 9 way Clipper plug) through the tube.

An optional 0.5 Metre Aluminium mounting tube pre-drilled with equally spaced tapped holes is available from Gill Instruments (Part 1405-30-056).

**Note:** the customer must fit appropriate strain relief to the cable.

Connect the plug by twisting it whilst pushing it gently into the socket on the MaxiMet. When it locates, twist the outer sleeve clockwise to connect and lock the plug.

Fix the MaxiMet to the tube using the 3 stainless steel screws provided. (Maximum mounting screw torque 1.5 Nm for Aluminium tubes and 3Nm for Stainless Steel Tubes).

For hostile environments, you should select a material suitable for the intended environment. For example, stainless steel 316 for marine use.

For non-hostile environments an Aluminium tube can be used.

### 5.1.9 Mounting Bracket e.g. Gill Part 1771-PK-115

An optional Mounting bracket is available from Gill Instruments Part 1771-PK-115 as per the illustration.

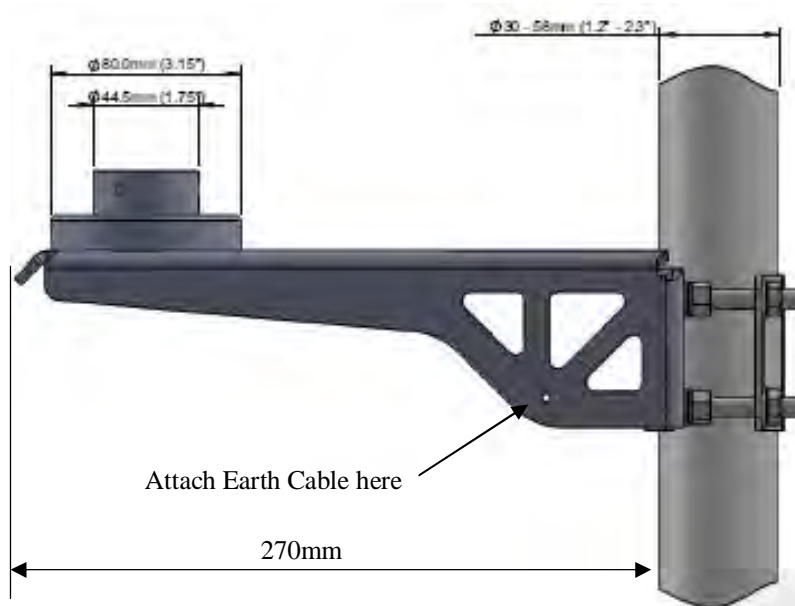

1. Mount the Sensor on to the bracket mount and if using a MaxiMet Wind Sensor, align so that the Sensor North Marker points to the bracket pole.
2. Secure the sensor to its mount using screws and washers supplied in the MaxiMet Box.
3. Torque screws to a maximum of 1.5 Nm.

The Bracket uses a mounting clamp suitable for attaching to a vertical pipe with a diameter of 30-58mm. When mounting the MaxiMet, consider the position, orientation and alignment of the unit. Mount at the top of a Pipe to ensure a clear unobstructed measurement view.

**Note:-** The mounting pipe should first be degreased and when assembling the Bracket clamp assembly the outer clamp nuts need to be tightened evenly to a torque figure of 3 Nm.

The moving plate part of the clamp needs to be reversed for poles below 38 mm diameter.

Screw an Earth cable minimum of 6mm<sup>2</sup> to the Bracket chassis using Screw and Terminal Tag fixings supplied.

**5.1.10 Dimensions (in mm)**

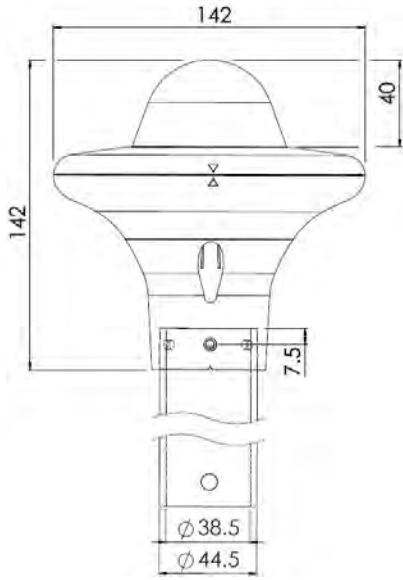

GMX100

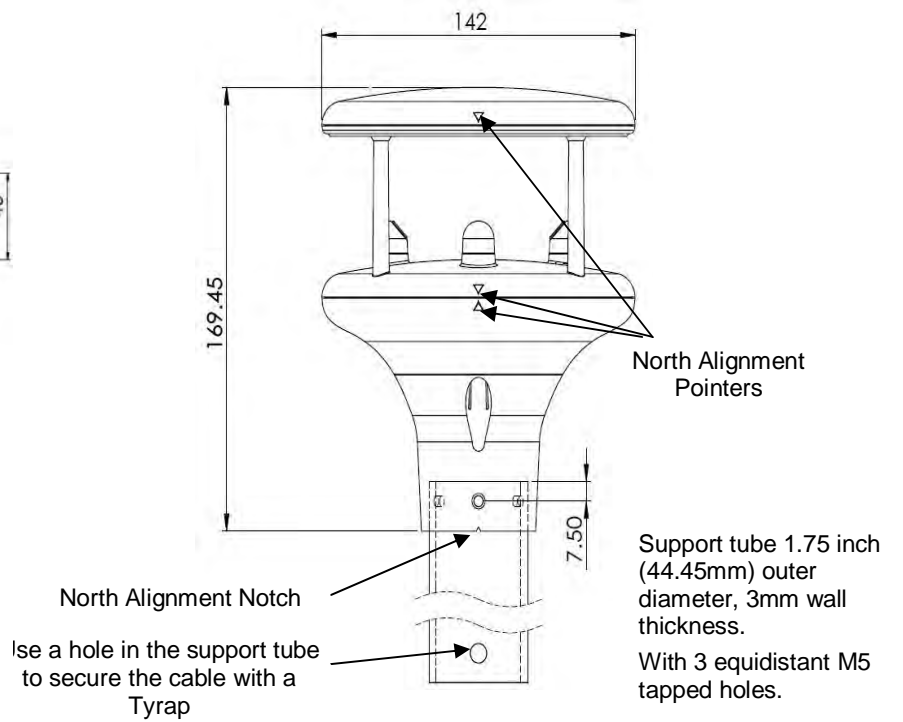

GMX200

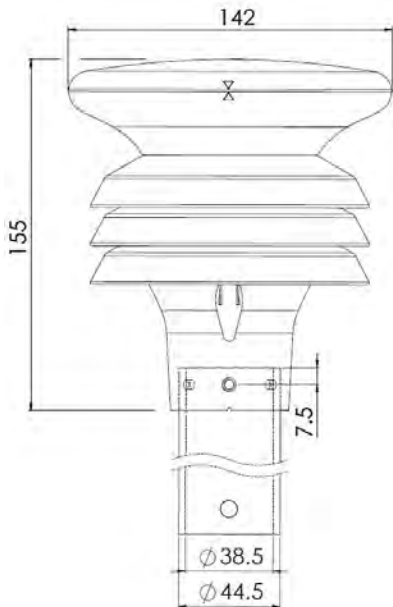

GMX300

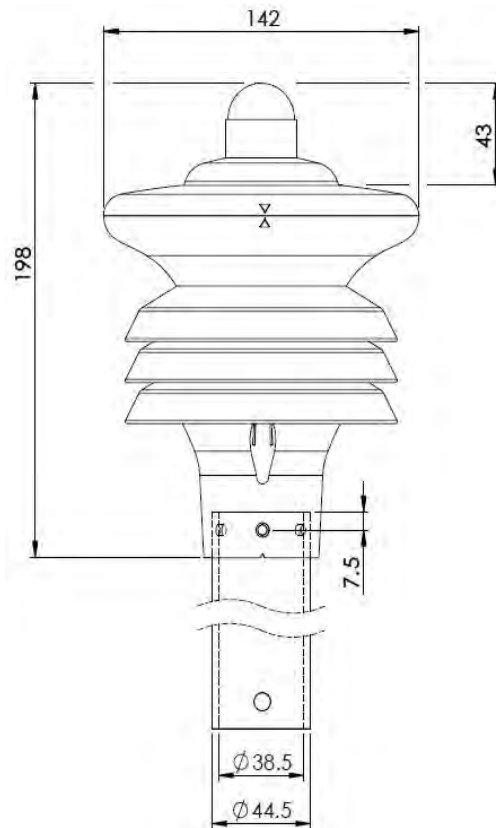

GMX301

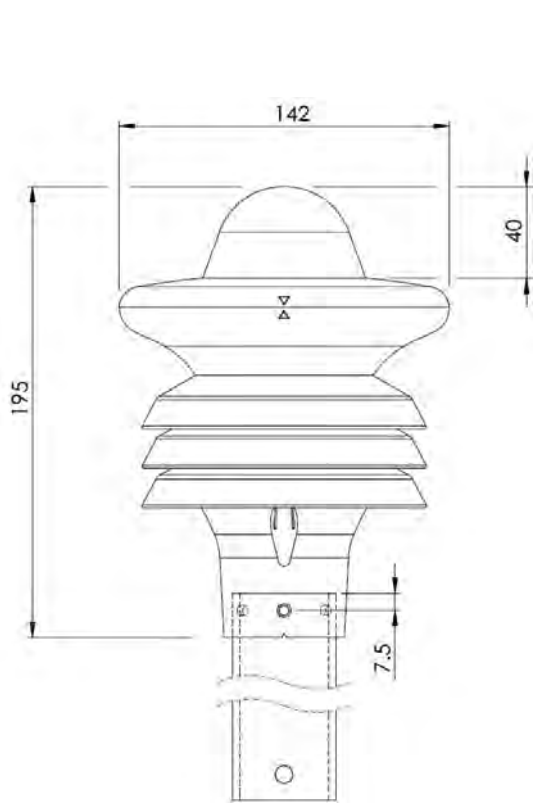

GMX400

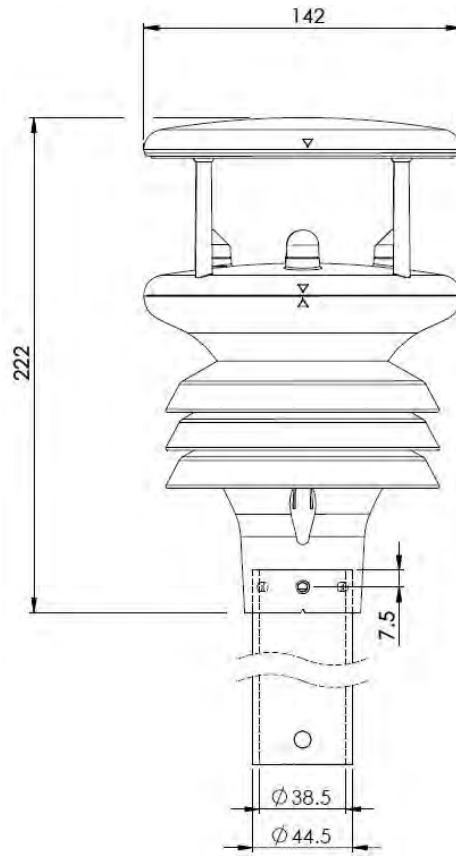

GMX500

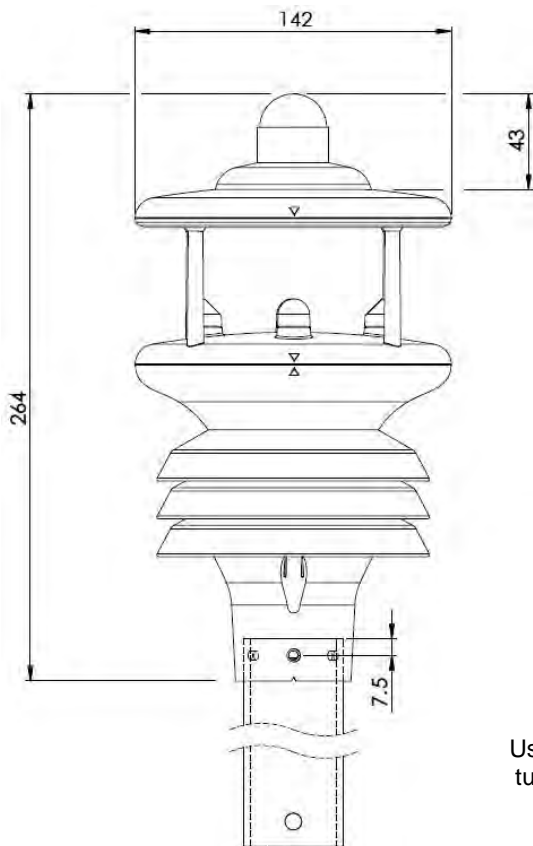

GMX501

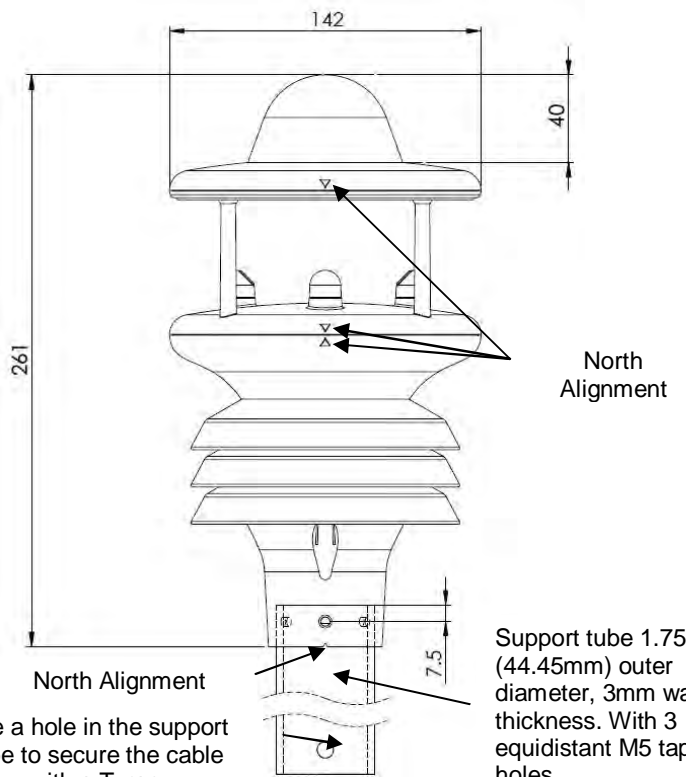

GMX600

Support tube 1.75 inch (44.45mm) outer diameter, 3mm wall thickness. With 3 equidistant M5 tapped holes.

North Alignment

Use a hole in the support tube to secure the cable with a Tyrap

## 6. CONFIGURING WITH METSET

MaxiMet can be configured using Gill Instruments MetSet Software which is loaded on the CD supplied with MaxiMet.

MetSet software can run on PC's running up to and including Windows 10 and can also be downloaded from the Gill Website:-

<http://www.gillinstruments.com/main/software.html>.

### 6.1. MaxiMet Default Configurations

#### GMX100 Factory Default Data String

NODE, TOTAL, PRECIP, PRECIP, INTENSITY, TIME, VOLT, STATUS, CHECK.

␣ Q, 00000.2,000.2,2015-06-05T10:19:30.8,+05.1,0000,␣ 36

Where

␣	STX
Q	Node Letter
00000.2	Precipitation Total
000.2	Precipitation Intensity
2015-06-05	Date
T10:19:30.8	Time
+05.1	Supply Voltage
0000	Status
␣	ETX
36	Checksum

NOTES:

<STX> is the Start of String character (ASCII value 2).

<ETX> is the End of String character (ASCII value 3).

Checksum, the 2 digit Hex Checksum sum figure is calculated from the Exclusive OR of the bytes between (and not including) the STX and ETX characters

The Status code will always read 0000 and has no functionality within a MaxiMet GMX100.

MetSet Default Settings

REPORT : NODE TOTAL PRECIP PRECIP INTENSITY TIME VOLT STATUS CHECK		
PROTOCOL : GILL	PRECIPITATION SENSOR : ON	POWER : 0
COMMS : RS232	PRECIPITATION UNITS : MM	TIME : 2015-06-05T11:04:54
BAUD : 19200		AUTOTIME : ON
NODE : Q		TZOFFSET : +00.00
OUTFREQ : 1HZ		PUPMSG STATUS : ON
MSGMODE : CONT		PUPMSG REPORT : ON
ASCTERM : CRLF		PUPMSG UNITS : ON
ECHO : ON		MODBUS : RTU
		MODADDR : 1
		DATABITS : 8
		STOPBITS : 1
		PARITY : NONE
		MODTERM : 10
		MODICT : 1000

## GMX200 Factory Default Data String:

Items in red relate to the GPS option unit.

NODE, DIR, SPEED, CDIR, **CSPEED, GPSLOCATION**, TIME, VOLT, STATUS, CHECK

␣ Q,021,000.01,090,000.01,+50.763004:-001.539898:+3.10,2015-06-05T10:19:30.8,  
+05.1,0000,␣ 36

Where:-

␣	STX
Q	Node Letter
021	Wind Direction
000.01	Wind Speed
090	Corrected Direction
<b>000.01</b>	<b>GPS Corrected Speed</b>
<b>+50.763004</b>	<b>GPS Latitude</b>
<b>-001.539898</b>	<b>GPS Longitude</b>
<b>+3.10</b>	<b>GPS Height location</b>
2015-06-05	Date
T10:19:30.8	Time
+05.1	Supply Voltage
0000	Status
␣	ETX
36	Checksum

NOTES: <STX> is the Start of String character (ASCII value 2).  
<ETX> is the End of String character (ASCII value 3).  
Checksum, the 2 digit Hex Checksum sum figure is calculated from the Exclusive OR of the bytes between (and not including) the STX and ETX characters.

### MetSet Settings Summary

REPORT : NODE DIR SPEED CDIR <b>CSPEED GPSLOCATION</b> TIME VOLT STATUS CHECK		
PROTOCOL : GILL	SENSOR COMPASS : ON	POWER : 0
COMMS : RS232	COMPASSDECL : +000.0	TIME : 2015-06-05T11:04:54
BAUD : 19200	<b>SENSOR GPS : ON</b>	AUTOTIME : ON
NODE : Q	<b>UNITS GPS : MS</b>	TZOFFSET : +00.00
OUTFREQ : 1HZ		PUPMSG STATUS : ON
MSGMODE : CONT		PUPMSG REPORT : ON
ASCTERM : CRLF		PUPMSG UNITS : ON
ECHO : ON		MODBUS : RTU
ALIGN : 0		MODADDR : 1
SENSOR WIND : ON		DATABITS : 8
UNITS WIND : MS		STOPBITS : 1
NODIR : 0.00		PARITY : NONE
AVGSHORT : 60		MODTERM : 10
AVGLONG : 10		MODICT : 1000

**GMX300 Factory Default Data String:**

NODE, PRESS, RH, TEMP, DEWPOINT, TIME, VOLT, STATUS, CHECK

␣ Q, 1015.3,041,+022.0,+008.5,2015-06-05T10:19:30.8,+05.1,0000,␣ 36

Where

␣	STX
Q	Node Letter
1015.3	Pressure
041	Relative Humidity
+022.0	Temperature
+008.5	Dewpoint
2015-06-05	Date
T10:19:30.8	Time
+05.1	Supply Voltage
0000	Status
␣	ETX
36	Checksum

**NOTES:**

<STX> is the Start of String character (ASCII value 2).

<ETX> is the End of String character (ASCII value 3).

Checksum, the 2 digit Hex Checksum sum figure is calculated from the Exclusive OR of the bytes between (and not including) the STX and ETX characters.

**MetSet Default Settings**

REPORT : NODE PRESS RH TEMP DEWPOINT TIME VOLT STATUS CHECK		
PROTOCOL : GILL	SENSOR TEMP : ON	POWER : 0
COMMS : RS232	UNITS TEMP : C	TIME : 2015-06-05T11:04:54
BAUD : 19200	SENSOR DEWPOINT : ON	AUTOTIME : ON
NODE : Q	UNITS DEWPOINT : C	TZOFFSET : +00.00
OUTFREQ : 1HZ	SENSOR PRESS : ON	PUPMSG STATUS : ON
MSGMODE : CONT	UNITS PRESS : HPA	PUPMSG REPORT : ON
ASCTERM : CRLF	HASL : +00000.00	PUPMSG UNITS : ON
ECHO : ON	HASTN : +00000.00	MODBUS : RTU
ALIGN : 0	SENSOR RH : ON	MODADDR : 1
	UNITS RH : %	DATABITS : 8
		STOPBITS : 1
		PARITY : NONE
		MODTERM : 10
		MODICT : 1000

## GMX301 Factory Default Data String:

NODE, PRESS, RH, TEMP, DEWPOINT, SOLARRAD, TIME, VOLT, STATUS, CHECK

␣ Q,1015.3,041,+022.0,+008.5,0000,2015-06-05T10:19:30.8,+05.1,0004,␣ 36

Where

␣	STX
Q	Node Letter
1015.3	Pressure
041	Relative Humidity
+022.0	Temperature
+008.5	Dewpoint
0000	Solar Radiation
2015-06-05	Date
T10:19:30.8	Time
+05.1	Supply Voltage
0004	Status
␣	ETX
36	Checksum

### NOTES:

<STX> is the Start of String character (ASCII value 2).

<ETX> is the End of String character (ASCII value 3).

Checksum, the 2 digit Hex Checksum sum figure is calculated from the Exclusive OR of the bytes between (and not including) the STX and ETX characters.

### MetSet Settings Summary

REPORT : NODE PRESS RH TEMP DEWPOINT SOLARRAD TIME VOLT STATUS CHECK		
PROTOCOL : GILL	SENSOR COMPASS : ON	POWER : 0
COMMS : RS232	COMPASSDECL : +000.0	TIME : 2015-06-05T11:04:54
BAUD : 19200	SENSOR TEMP : ON	AUTOTIME : ON
NODE : Q	UNITS TEMP : C	TZOFFSET : +00.00
OUTFREQ : 1HZ	SENSOR DEWPOINT : ON	PUPMSG STATUS : ON
MSGMODE : CONT	UNITS DEWPOINT : C	PUPMSG REPORT : ON
ASCTERM : CRLF	SENSOR PRESS : ON	PUPMSG UNITS : ON
ECHO : ON	UNITS PRESS : HPA	MODBUS : RTU
ALIGN : 0	HASL : +00000.00	MODADDR : 1
	HASTN : +00000.00	DATABITS : 8
	SENSOR RH : ON	STOPBITS : 1
	UNITS RH : %	PARITY : NONE
	SENSOR SOLAR : ON	MODTERM : 10
		MODICT : 1000

## GMX400 Factory Default Data String

: NODE, PRESS, RH, TEMP, DEWPOINT, TOTAL, PRECIP, PRECIP, INTENSITY, TIME, VOLT, STATUS,CHECK.

␣ Q,1015.3,041,+022.0,+008.5,00000.2,000.2,2015-06-05T10:19:30.8,+05.1,0000,␣ 36

Where

␣	STX
Q	Node Letter
1015.3	Pressure
041	Relative Humidity
+022.0	Temperature
+008.5	Dewpoint
0000.2	Precipitation Total
000.2	Precipitation Intensity
2015-06-05	Date
T10:19:30.8	Time
+05.1	Supply Voltage
0000	Status
␣	ETX
36	Checksum

### NOTES:

<STX> is the Start of String character (ASCII value 2).

<ETX> is the End of String character (ASCII value 3).

Checksum, the 2 digit Hex Checksum sum figure is calculated from the Exclusive OR of the bytes between (and not including) the STX and ETX characters

### MetSet Default Settings

REPORT : PRESS RH TEMP DEWPOINT TOTAL PRECIP PRECIP INTENSITY TIME VOLT STATUS CHECK		
PROTOCOL : GILL	SENSOR TEMP : ON	POWER : 0
COMMS : RS232	UNITS TEMP : C	TIME : 2015-06-05T11:04:54
BAUD : 19200	SENSOR DEWPOINT : ON	AUTOTIME : ON
NODE : Q	UNITS DEWPOINT : C	TZOFFSET : +00.00
OUTFREQ : 1HZ	SENSOR PRESS : ON	PUPMSG STATUS : ON
MSGMODE : CONT	UNITS PRESS : HPA	PUPMSG REPORT : ON
ASCTERM : CRLF	HASL : +00000.00	PUPMSG UNITS : ON
ECHO : ON	HASTN : +00000.00	MODBUS : RTU
ALIGN : 0	SENSOR RH : ON	MODADDR : 1
	UNITS RH : %	DATABITS : 8
	PRECIPITATION SENSOR : ON	STOPBITS : 1
	PRECIPITATION UNITS : MM	PARITY : NONE
		MODTERM : 10
		MODICT : 1000

**GMX500 Factory Default Data String:**

Items in red relate to the GPS option unit.

NODE, DIR, SPEED, CDIR, **CSPEED**, PRESS, RH, TEMP, DEWPOINT, **GPSLOCATION**, TIME, VOLT, STATUS, CHECK

␣ Q,021,000.01,090,**000.01**,1015.3,041,+022.0,+008.5,**+50.763004:-001.539898:+3.10**,2015-06-05T10:19:30.8,+05.1,0004,␣ 36

Where

␣	STX
Q	Node Letter
021	Wind Direction
000.01	Wind Speed
090	Corrected Direction
<b>000.01</b>	<b>GPS Corrected Speed</b>
1015.3	Pressure
041	Relative Humidity
+022.0	Temperature
+008.5	Dewpoint
<b>+50.763004</b>	<b>GPS Latitude</b>
<b>-001.539898</b>	<b>GPS Longitude</b>
<b>+3.10</b>	<b>GPS Height location</b>
2015-06-05	Date
T10:19:30.8	Time
+05.1	Supply Voltage
0004	Status
␣	ETX
36	Checksum

**NOTES:**

<STX> is the Start of String character (ASCII value 2).

<ETX> is the End of String character (ASCII value 3).

Checksum, the 2 digit Hex Checksum sum figure is calculated from the Exclusive OR of the bytes between (and not including) the STX and ETX characters.

**MetSet Default Settings**

REPORT : NODE DIR SPEED CDIR <b>CSPEED</b> PRESS RH TEMP DEWPOINT <b>GPSLOCATION</b> TIME VOLT STATUS CHECK		
PROTOCOL : GILL	SENSOR COMPASS : ON	POWER : 0
COMMS : RS232	COMPASSDECL : +000.0	TIME : 2015-06-05T11:04:54
BAUD : 19200	<b>SENSOR GPS : ON</b>	AUTOTIME : ON
NODE : Q	<b>UNITS GPS : MS</b>	TZOFFSET : +00.00
OUTFREQ : 1HZ	SENSOR TEMP : ON	PUPMSG STATUS : ON
MSGMODE : CONT	UNITS TEMP : C	PUPMSG REPORT : ON
ASCTERM : CRLF	SENSOR DEWPOINT : ON	PUPMSG UNITS : ON
ECHO : ON	UNITS DEWPOINT : C	MODBUS : RTU
ALIGN : 0	SENSOR PRESS : ON	MODADDR : 1
SENSOR WIND : ON	UNITS PRESS : HPA	DATABITS : 8
UNITS WIND : MS	HASL : +00000.00	STOPBITS : 1
NODIR : 0.00	HASTN : +00000.00	PARITY : NONE
AVGSHORT : 60	SENSOR RH : ON	MODTERM : 10
AVGLONG : 10	UNITS RH : %	MODICT : 1000

**GMX501 Factory Default Data String:**

Items in red relate to the GPS Option Unit.

NODE, DIR, SPEED, CDIR, **CSPEED**, PRESS, RH, TEMP, DEWPOINT, SOLARRAD, **GPSLOCATION**, TIME, VOLT, STATUS, CHECK

␣ Q,021,000.01,090,**000.01**,1015.3,041,+022.0,+008.5,0000,**+50.763004:-001.539898:+3.10**,2015-06-05T10:19:30.8,+05.1,0004,␣ 36

Where

␣	STX
Q	Node Letter
021	Wind Direction
000.01	Wind Speed
090	Corrected Direction
<b>000.01</b>	<b>GPS Corrected Speed</b>
1015.3	Pressure
041	Relative Humidity
+022.0	Temperature
+008.5	Dewpoint
0000	Solar Radiation
<b>+50.763004</b>	<b>GPS Latitude</b>
<b>-001.539898</b>	<b>GPS Longitude</b>
<b>+3.10</b>	<b>GPS Height location</b>
2015-06-05	Date
T10:19:30.8	Time
+05.1	Supply Voltage
0004	Status
␣	ETX
36	Checksum

**NOTES:**

<STX> is the Start of String character (ASCII value 2).

<ETX> is the End of String character (ASCII value 3).

Checksum, the 2 digit Hex Checksum sum figure is calculated from the Exclusive OR of the bytes between (and not including) the STX and ETX characters.

**MetSet Default Settings**

REPORT : NODE DIR SPEED CDIR <b>CSPEED</b> PRESS RH TEMP DEWPOINT SOLARRAD <b>GPSLOCATION</b> TIME VOLT STATUS CHECK		
PROTOCOL : GILL	SENSOR COMPASS : ON	POWER : 0
COMMS : RS232	COMPASSDECL : +000.0	TIME : 2015-06-05T11:04:54
BAUD : 19200	<b>SENSOR GPS : ON</b>	AUTOTIME : ON
NODE : Q	<b>UNITS GPS : MS</b>	TZOFFSET : +00.00
OUTFREQ : 1HZ	SENSOR TEMP : ON	PUPMSG STATUS : ON
MSGMODE : CONT	UNITS TEMP : C	PUPMSG REPORT : ON
ASCTERM : CRLF	SENSOR DEWPOINT : ON	PUPMSG UNITS : ON
ECHO : ON	UNITS DEWPOINT : C	MODBUS : RTU
ALIGN : 0	SENSOR PRESS : ON	MODADDR : 1
SENSOR WIND : ON	UNITS PRESS : HPA	DATABITS : 8
UNITS WIND : MS	HASL : +00000.00	STOPBITS : 1
NODIR : 0.00	HASTN : +00000.00	PARITY : NONE
AVGSHORT : 60	SENSOR RH : ON	MODTERM : 10
AVGLONG : 10	UNITS RH : %	MODICT : 1000
	SENSOR SOLAR : ON	

## GMX600 Factory Default Data String

Items in red relate to the GPS Option Unit.

: NODE DIR SPEED CDIR **CSPEED** PRESS RH TEMP DEWPOINT TOTAL PRECIP PRECIP INTENSITY **GPSLOCATION** TIME VOLT STATUS CHECK

⌋ Q,021,000.01,090,**000.01**,1015.3,041,+022.0,+008.5, 0000.2,000.2,**+50.763004:-001.539898:+3.10**,2015-06-05T10:19:30.8,+05.1,0004,⌋ 36

Where

⌋	STX
Q	Node Letter
021	Wind Direction
000.01	Wind Speed
090	Corrected Direction
<b>000.01</b>	<b>GPS Corrected Speed</b>
1015.3	Pressure
041	Relative Humidity
+022.0	Temperature
+008.5	Dewpoint
0000.2	Precipitation Total
000.2	Precipitation Intensity
<b>+50.763004</b>	<b>GPS Latitude</b>
<b>-001.539898</b>	<b>GPS Longitude</b>
<b>+3.10</b>	<b>GPS Height location</b>
2015-06-05	Date
T10:19:30.8	Time
+05.1	Supply Voltage
0004	Status
⌋	ETX
36	Checksum

### NOTES:

<STX> is the Start of String character (ASCII value 2).

<ETX> is the End of String character (ASCII value 3).

Checksum, the 2 digit Hex Checksum sum figure is calculated from the Exclusive OR of the bytes between (and not including) the STX and ETX characters

### MetSet Default Settings

REPORT : NODE DIR SPEED CDIR <b>CSPEED</b> PRESS RH TEMP DEWPOINT TOTAL PRECIP PRECIP INTENSITY <b>GPSLOCATION</b> TIME VOLT STATUS CHECK		
PROTOCOL : GILL	SENSOR COMPASS : ON	POWER : 0
COMMS : RS232	COMPASSDECL : +000.0	TIME : 2015-06-05T11:04:54
BAUD : 19200	<b>SENSOR GPS : ON</b>	AUTOTIME : ON
NODE : Q	<b>UNITS GPS : MS</b>	TZOFFSET : +00.00
OUTFREQ : 1HZ	SENSOR TEMP : ON	PUPMSG STATUS : ON
MSGMODE : CONT	UNITS TEMP : C	PUPMSG REPORT : ON
ASCTERM : CRLF	SENSOR DEWPOINT : ON	PUPMSG UNITS : ON
ECHO : ON	UNITS DEWPOINT : C	MODBUS : RTU
ALIGN : 0	SENSOR PRESS : ON	MODADDR : 1
SENSOR WIND : ON	UNITS PRESS : HPA	DATABITS : 8
UNITS WIND : MS	HASL : +00000.00	STOPBITS : 1
NODIR : 0.00	HASTN : +00000.00	PARITY : NONE
AVGSHORT : 60	SENSOR RH : ON	MODTERM : 10
AVGLONG : 10	UNITS RH : %	MODICT : 1000
	PRECIPITATION SENSOR : ON	
	PRECIPITATION UNITS : MM	

## 6.2. Configuring MaxiMet with MetSet

Install MetSet software on to a PC from the supplied CD or download MetSet from the Gill Website at:-

<http://gillinstruments.com/main/software.html>

Before you use MetSet check that MaxiMet is correctly connected to a Serial COM port or USB COM port on your PC (maximum COM port number 50 accepted by MetSet).

The optional Gill, 1.8M, RS232 to USB cable (1957-10-065) can be used to power and provide a suitable communication link for configuring a MaxiMet unit.

### NOTES:

MetSet is compatible with RS232 and RS422 connected units with ASCII and NMEA outputs only.

Use Safe Mode if connected to units set for SDI-12 or Modbus Outputs to read/change settings.

**The availability of certain functions and parameters illustrated will depend on the MaxiMet model and Options see Page 6, Para 2.1.2.**

### 6.2.1 Opening MetSet

Click on the MetSet button on your PC's desktop or choose:

**Start > All Programs > MetSet > MetSet**

The MetSet Control Centre window is displayed. If you have more than one MaxiMet connected to your PC, MetSet, by default, selects the first device detected.

For most applications it is recommended to click on the MetSet **Connect and Read** button.

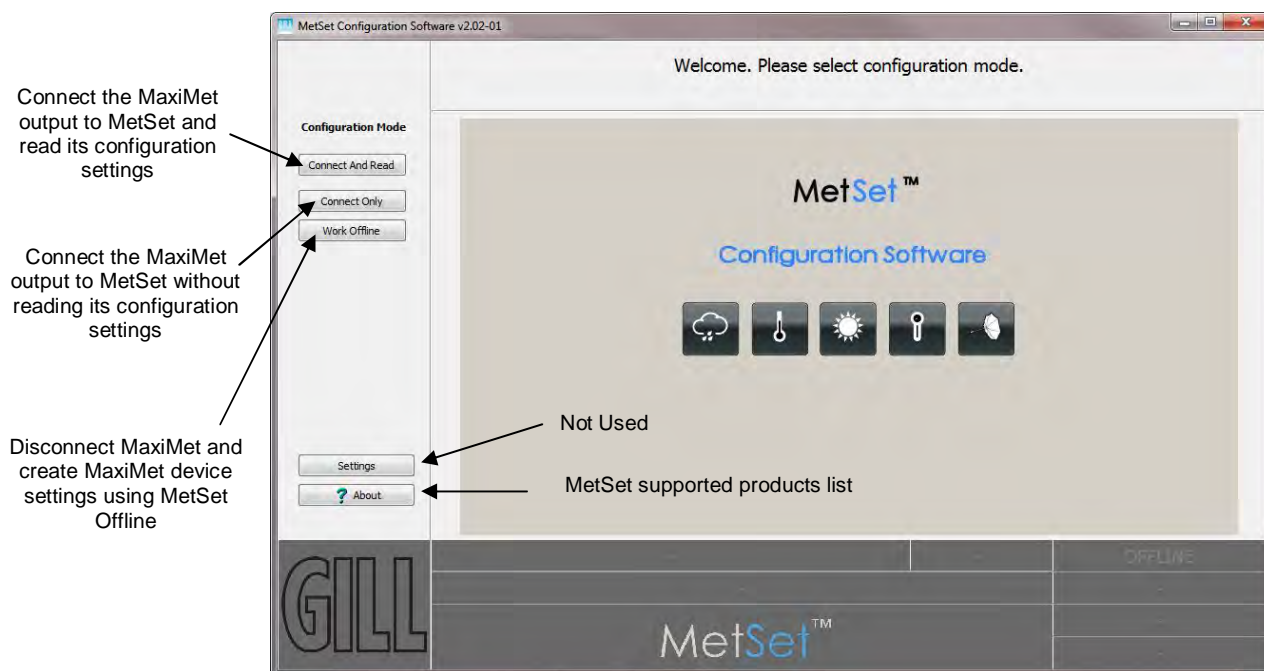

Figure 1 Opening MetSet Screen

MetSet interrogates the MaxiMet and returns a summary of the device settings.

Depending on the MaxiMet Sensor connected only settings and parameters appropriate to the connected MaxiMet unit will be shown.

**Note** that MetSet also saves a copy of this screen to the connected PC as a Session Report File that can be accessed from the following destination.

C:\GillAppsData\Metset\SessionReports.

---

Example Summary of MaxiMet Device Settings (GMX600 with GPS option shown):-

SETTINGS ARE AS FOLLOWS:

PROTOCOL : GILL  
COMMS : RS232  
(BAUD) : 19200  
NODE : Q  
OUTFREQ : 1HZ  
MSGMODE : CONT  
ASCTERM : CRLF  
ECHO : ON  
ALIGN : 0  
SENSOR WIND : ON  
UNITS WIND : MS  
NODIR : 0.00  
AVGSHORT : 60  
AVGLONG : 10  
SENSOR COMPASS : ON  
COMPASSDECL : +000.0  
SENSOR GPS : ON  
UNITS GPS : MS  
SENSOR TEMP : ON  
UNITS TEMP : C  
SENSOR DEWPOINT : ON  
UNITS DEWPOINT : C  
SENSOR PRESS : ON  
UNITS PRESS : HPA  
HASL : +00000.00  
HASTN : +00000.00  
SENSOR RH : ON  
UNITS RH : %  
SENSOR PRECIP : ON  
UNITS PRECIP : MM  
ARPRECIP : ON  
REPORT : NODE DIR SPEED CDIR CSPEED PRESS RH TEMP DEWPOINT PRECIPT PRECIPI GPSLOCATION TIME VOLT STATUS  
POWER : 0  
TIME : 2016-04-15T12:30:57  
AUTOTIME : ON  
TZOFFSET : +00.00  
PUPMSG STATUS : ON  
PUPMSG REPORT : ON  
PUPMSG UNITS : ON  
MODBUS : RTU  
MODADDR : 1  
DATABITS : 8  
STOPBITS : 1  
PARITY : EVEN  
MODTERM : 10  
MODICT : 1000

Note changes to BAUD, COMMS or PROTOCOL settings will take place after next power-up.

Click on the Close button to continue to the MetSet set up screen.

## 6.2.2 MetSet Editing Screen

When connected correctly a MetSet editing screen is available to read configuration settings, change configuration settings, save MaxiMet configuration settings to a PC file location, upload MaxiMet configuration settings from a PC file and view the MaxiMet raw data string output.

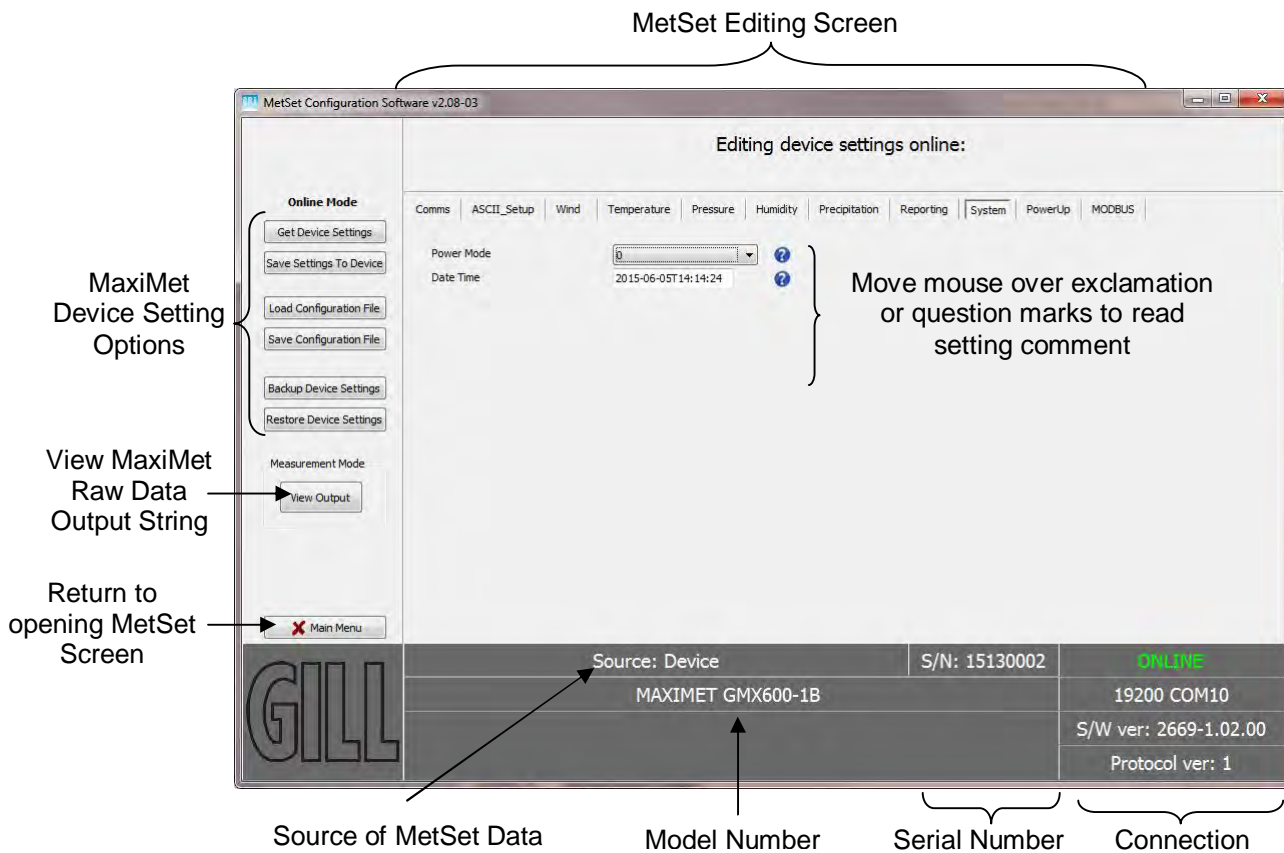

### • MetSet Connection Status Information.

Reading	Function
ONLINE	ONLINE in green indicates the MaxiMet has been successfully connected to MetSet. OFFLINE in Grey indicates that MetSet is being used without a MaxiMet in communication with MetSet.
19200 COM10	19200 is a report on the MaxiMet Baud rate setting. COM 10 is a report on the MaxiMet COM Port connection number.
S/W ver 2669-1.02.00	2669 is the MaxiMet Firmware number. 1.02.00 is the firmware revision. PV=1 is the Protocol Version (Gill Internal Reference).
Source:Device	MetSet reads 'Device' when the source of the data that MetSet has retrieved has come from the MaxiMet and the MaxiMet Model. MetSet reads 'File' when the source of data has come from a saved file. MetSet reports on the connected MaxiMet device (MAXIMET GMX600-1B) and reads the unit Serial Number (S/N: 15130002)

### 6.2.3 MetSet Online Settings.

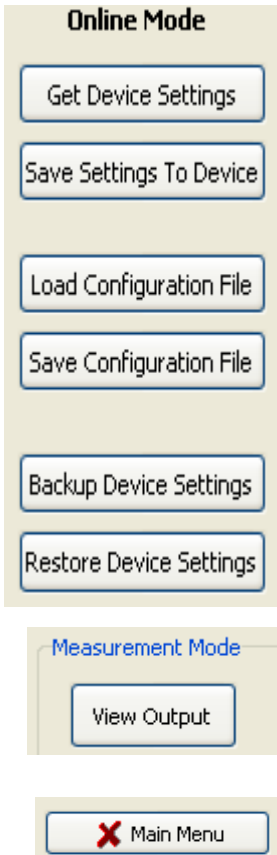

Online Mode Buttons	Function
Get Device Settings	MetSet retrieves the MaxiMet Configuration settings.
Save Settings to Device	MetSet configuration settings are saved to a connected MaxiMet.
Load Configuration File	When selected MetSet retrieves a MetSet edit PC file and updates MetSet with these settings.
Save Configuration File	When selected MetSet edit settings are saved to a PC file location.
Back Up Device Settings	When selected the MaxiMet configuration settings are transferred to MetSet and then to a file location selected on a PC.
Restore Device Settings	When selected MetSet retrieves a MaxiMet configuration setting from a PC file, loads it into the MaxiMet and updates the MetSet edit settings.
Measurement Mode View Output	Click on View Output to view the raw ASCII MaxiMet data string scrolling at the output rate. (View only feature). E.g. Q,127,000.03,000,2000-01-01T00:40:50.2,+10.5,0000, 21
Main Menu	Click here to go back to the opening MetSet screen

## 6.2.4 MetSet Editing Pages.

**Features and Parameters available to view and select will depend on the MaxiMet model connected. See page 6 for a summary of available sensor outputs and parameters.**

NOTE: Items shown in Bold are the default settings.

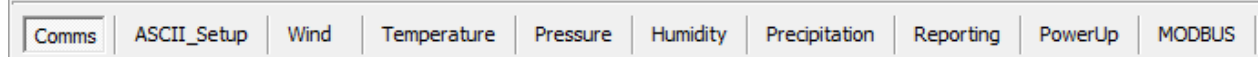

The Comms Page can be used to Select:-

Protocol	GILL	
Interface	RS232	
Baud Rate	19200	
Node ID	Q	
Output rate	1HZ	
Message Mode	CONT	

- Protocol:- **GILL**, MODBUS or SDI-12 (for SDI-12 also set MetSet Comms/Interface to SDI-12).
- Interface:- **RS232**, RS422, RS485P2W (point to point) ,SDI-12 and EXT.  
EXT setting means RS422 or RS232 selected by a wire link on connector pin 8 (see Para 4.4.2).
- Baud Rate:- 4800, 9600, **19200**, 38400 or 57600  
(1200 auto selected with SDI-12 setting).
- Node ID:- A to P, **Q** to Z.
- Output Rate:- **1Hz (1 per second)**, Once per Minute, Once per Hour .
- Message Mode:- **CONT** (Continuous output) or POLL (Polled Mode).

### NOTES:











**When COMMS or Baud Rate settings are changed and Saved to Device a warning is issued by MetSet. These setting changes will not become active until the MaxiMet power is turned off and turned on again. The connecting device will then also need its Comms and Baud rate settings changed to match the MaxiMet.**

**When selecting Modbus then Message Mode must be set for CONT.**

The ASCII Set up Page can be used to select:-

- Termination:- **CRLF** or CR
- Echo:- **ON** or OFF.

The **Wind Page** can be used to select:-

Comms	ASCII_Setup	Wind	Temperature	Pressure	Humidity
North Alignment		<input type="text" value="0"/>			
Sensor Windspeed		<input type="button" value="ON"/>			
Wind speed Units		<input type="button" value="MS"/>			
No-Direction Wind Speed		<input type="text" value="0.00"/>			
Short Term Average		<input type="text" value="60"/>			
Long Term Average		<input type="text" value="10"/>			
Compass Sensor		<input type="button" value="ON"/>			
Compass Declination		<input type="text" value="+000.0"/>			
GPS Sensor		<input type="button" value="ON"/>			
GPS Speed Units		<input type="button" value="MS"/>			

North Alignment from **0-359** degrees.

Sensor WindSpeed **ON** or OFF.

Wind Speed Units **MS**, KTS, MPH, KPH, FPM.

(Metres/Second, Knots (Nautical miles/hour), Miles/Hour, Kilometres/Hour, Feet/Minute).

No-Direction Wind Speed **0.00m/s** to 5.00m/s speed above which direction readings are output.

Short Term Average **60** (10-60).

Configures WMO Short Term Average as the defined multiple of the Output rate .i.e. AVGSHORT 10 is a rolling average of the last ten outputs.

Long Term Average **10** (1-10).

Configures WMO Long Term Average as the defined multiple of the short Term Average.

i.e. if AVGSHORT is 10 then short term average is a rolling average of the last ten outputs.

Then if AVGLONG is set to 10, long term average is a rolling average of the last 100 outputs.

Compass Sensor **ON** or OFF

With Compass Sensor ON Wind Direction readings corrected to magnetic north are output in the data string (CDIR). If set to OFF then the field with Compass corrected direction reading is left blank.

Compass Declination **+000.0**

Declination is the magnetic declination (the angle between Magnetic North and True North) in degrees.

This is a correction factor that is added to the magnetic north heading from the compass.

Map and declination figures in decimal figures can be obtained from:-

<http://www.geosats.com/magdecli.html>

<http://www.ngdc.noaa.gov/geomag/declination.shtml>

GPS Sensor **ON/OFF**, GPS sensor output.

GPS Speed Units **MS**, KTS, MPH, KPH, FPM.

## 6.2.5 WMO Average Wind Reading Notes:

Note: WMO averaged wind readings are disabled in MaxiMet power saving mode.

The default output rate from MaxiMet is one new reading every second.

In this case the WMO averaged Wind reading result will be based on:-

Long Term Average (1-10) x Short Term Average (10-60).

The direction and magnitude outputs are derived from the vector sum of U and V over the RWALONG averaging period (default 10 minutes with 1Hz Output rate).

The gust output is derived from the vector sum of U and V over 3 readings (3 seconds with a 1 Hz output rate), and the max gust is the maximum of the gust value over the RWASHORT period (default 60 seconds with a 1Hz output rate). The max gust value is reset to zero at the end of each RWASHORT period.

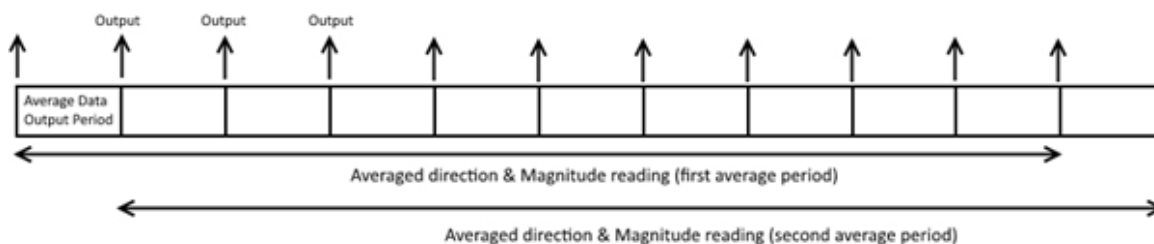

**RWA Default settings** are:-

**Output rate Hz** = 1  
**RWASHORT** = 60  
**RWALONG** = 10

Therefore:

**MaxiMet output period** =  $60/1 = 60$  seconds (the MaxiMet will output a reading every 60 seconds).

**Averaged direction and magnitude reading** =  $10 \times 60 = 600$  seconds (this is the time the readings will be averaged over).

When the average building period has been completed, the average reported thereafter will be a rolling average derived from the last averaged direction and magnitude time period.

For instance if a **2 minute averaged data** output was required set:-

RWA Long to 2

RWA Short to 60

For these settings then every minute you would get an averaged output reading based on the previous 2 minutes of wind data.

For instance if a **10 minute averaged data** output was required set:-

RWA Long to 10

RWA Short to 60

For these settings then every minute you would get an averaged output reading based on the previous 10 minutes of wind data.

To enable WMO averaged Wind readings in the MaxiMet data string select the Reporting Tab/USERDEF and add new reporting field from the drop down menu called:-

AVGSPEED	Outputs Average Speed readings.
AVGDIR	Outputs Average Direction Readings.
AVGCDIR	Outputs Average Corrected Direction Readings.

The maximum Gust Speed is the magnitude of the maximum gust measured over the short term output period. Gust is generated from a rolling 3s average of the short term output period, and reset at the end of short term output period.

**GSPEED** Outputs Average Wind Gust Speed.

The Maximum Gust Direction is the direction of the maximum gust measured over the short term output period. Gust is generated from a rolling 3s average of the short term output period, and reset at the end of short term output period.

**GDIR** Outputs Average Wind Gust Direction.

Whenever the unit is powered up then until the unit has reached its minimum long term averaging interval the Wind Status code will read 0100 (Measurement Average Building).

If MaxiMet is in Polled mode then when polled (default 1Hz output) MaxiMet will output the last valid 10 minute wind speed and direction average, updated every minute along with last valid 1 minute Gust magnitude, due to default WMO settings.

In polled mode, the last set of computed WMO measurements shall be output on receipt of a poll request.

In polled mode whilst a new WMO average is building, the last computed WMO average shall be output.

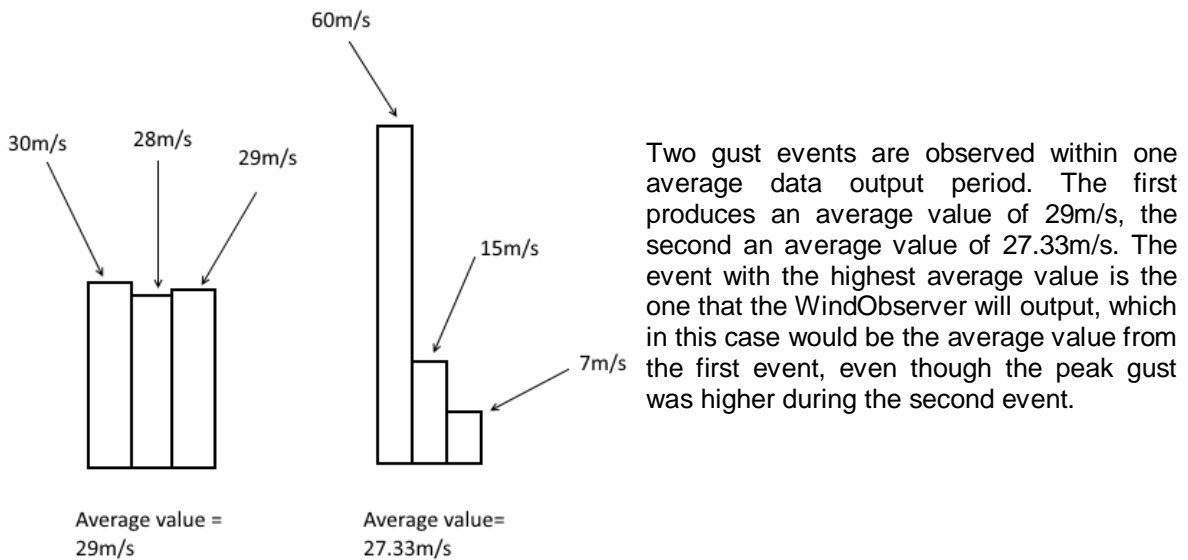

**The Temperature Page** can be used to select:-

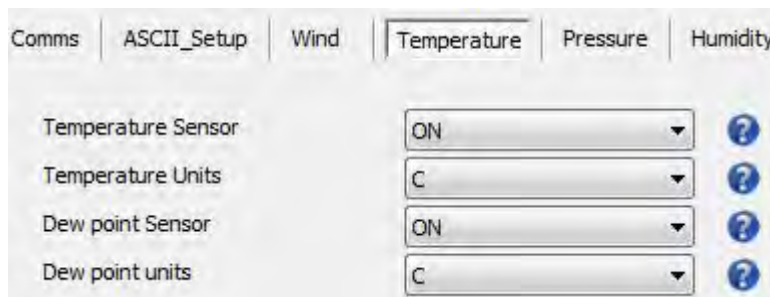

- Temperature Sensor **ON** or OFF
- Temperature Units **C**, K or F (Centigrade, Kelvin, Fahrenheit)
- Dew Point Sensor **ON** or OFF
- Dew Point Units **C**, K or F

**The Pressure Page** can be used to select:-

Pressure Sensor **ON** or OFF

Pressure Units **HPA**, MB, MMHG, INHG (Hecto Pascals, Milli-Bars, Millimetres Mercury, Inches Mercury).

Height Above Sea Level **+00000.00** (0 to 10000 Metres)

Is the elevation (on the ground) of the unit, relative to the average sea level point.

Atmospheric pressure varies with height above sea level as well as with atmospheric conditions. As the altitude at which the pressure sensor operates is usually constant (the station height), a correction is made to make the reading of the pressure sensor seem as if it were made at sea level. This means that the pressure reading has to be slightly increased from the value read by the MaxiMet sensor situated above sea level (often known as the station pressure).

Height Above Station **+00000.00** (-100 to +100 Metres)

The user can set the HASL figure together with the HASTN figure allows pressure at Sea Level to be calculated.

**The Humidity Page** can be used to select:-

Humidity Sensor **ON** or OFF

Humidity Units **%**

**The Precipitation (Rain) Page** can be used to select:-

Rain Sensor **ON** or OFF

Precipitation Units **MM** or IN (per hour)

Auto-reset Total Precipitation **ON** or OFF

ON resets the total precipitation reading to zero when the clock time reads 23:59:59 to 00 (midnight)

OFF results in continuous total precipitation measurement.

Note: for an indication of precipitation status in the data string (Y (yes) or N (no)) refer to the Reporting Page and select PRECIPS

**The Solar Page can be used to select:-**



Solar Sensor **ON** or OFF.

**The Reporting Page can be used to select:-**



Report Format **USERDEF**, DEFAULT, FULL or NMEA

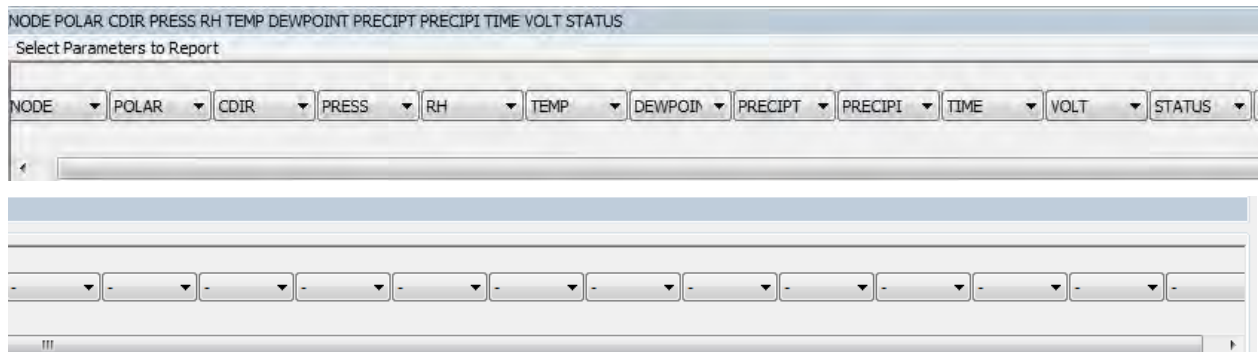

**Select Parameters to Report.**

**Actual reported parameters and order of output shown will depend on the MaxiMet Model and for more details on derived parameters refer to para 2.1.12.**

- DEFAULT        Sets the unit to report the factory set output parameters.
- FULL            Sets the unit to output every available sensor and derived parameter output.
- NMEA           Sets the unit to output an NMEA data string.

- USERDEF**      Report parameters can be selected in any order or on or off in USERDEF setting.
- NODE            Outputs a Node letter (A to Z).
- SPEED          Outputs wind speed readings.
- CSPEED         Outputs Corrected Speed if a GPS option is enabled.
- GSPEED         Outputs WMO Gust Speed.
- CGSPEED       Corrected Gust Speed if a GPS option is enabled.
- AVGSPEED      Outputs WMO average speed reading based on AVG short and AVG long settings.
- AVGCSPEED     Outputs WMO average corrected Speed reading using GPS based on AVG short and AVG long settings.
- DIR             Outputs wind direction readings.
- CDIR            Outputs Compass corrected wind direction readings.
- GDIR            Outputs WMO Gust Direction.
- CGDIR          Compass corrected WMO Gust Direction.

---

AVGDIR	Outputs WMO average direction reading based on AVG short and AVG long settings.
AVGCDIR	Outputs WMO average compass corrected direction reading based on AVG short and AVG long settings.
PRESS	Outputs the Barometric Pressure reading.
PASL	Outputs Barometric Pressure at Sea Level if HASL figure set (see page 43).
PSTN	Outputs Barometric Pressure at Station if HASTN figure set (see page 43).
RH	Outputs Relative Humidity reading.
AH	Outputs Absolute Humidity.
TEMP	Outputs the Temperature reading.
DEWPOINT	Outputs the Dewpoint reading.
PRECIPT	Outputs Precipitation (Rain) Total reading, this is an accumulated rain reading updated at the output rate (default 1Hz/ once per second). Is set to zero on MaxiMet power up. Is set to zero when the clock reads 23:59:59 to 00 (midnight) if Automatic Reset of Total Precipitation is set to ON (default setting).
PRECIPI	Outputs Precipitation (Rain) Intensity. It is the sum of the last sixty lots of 1 minute accumulated Rain data. A new sum measurement is generated every minute.
PRECIPS	Outputs Precipitation (Rain) Status as No (N) or Yes (Y). Changes N to Y when total precipitation is incremented. Changes Y to N when total precipitation has not incremented in the last 60 seconds.
SOLARRAD	Outputs the Solar Radiation Reading.
SOLARHOURS	Sunshine Hours.
COMPASSH	Compass Heading direction reading.
GPSHEADING	Outputs a GPS direction heading.
GPSSPEED	Outputs a GPS Speed over ground.
GPSLOCATION	Outputs Longitude, Latitude and GPS height.
GPSSTATUS	Outputs a location fix and the number of viewable satellites.
TIME	Outputs MaxiMet Date and Time.
VOLT	Outputs the MaxiMet Supply Voltage.
STATUS.	Outputs the MaxiMet Sensors Status Code (see para 8.3).
WINDSTAT	Outputs Status codes relating to Wind Sensor Data (see para 8.3).



**The MODBUS Page** can be used to select:-

Comms	ASCII_Setup	Wind	Temperature	Pressure	Humidity	Precipitation	Reporting	System	PowerUp	MODBUS
Mode	RTU									
Address	1									
Data bits	8									
Stop bits	1									
Parity	NONE									
Termination Char ASCII code	10									
Inter-char timeout (ms)	1000									

Mode	<b>RTU</b> or ASCII.
Address	<b>1</b> to 247.
Data Bits	<b>8 for Modbus RTU</b> , 7 for Modbus ASCII.
Stop Bits	<b>2 for No Parity</b> , 1 for Even/Odd Parity.
Parity	<b>NONE</b> , ODD, or EVEN.
Termination Char ASCII code	<b>10</b> , (0-255).
Inter Char Timeout (mS)	<b>1000</b> (500 to 10000).

### **6.3. Polled Mode**

To configure a MaxiMet unit for polled mode:

Connect a default set MaxiMet to a PC as described in Para 4.6.

Open MetSet as described on Para 6.2.

Click on the Edit Comms page and select:-

Set Protocol for required poll mode interface e.g. RS485 and

Set Message Mode to Poll.

Click on Save Settings to Device on the Online Mode Menu.

Shut down the MaxiMet unit.

Change the hardware connections for the required Poll Mode Interface.

#### **6.3.1 Power Saving Mode Disabled (MetSet System/Power Mode 0).**

The measurement rate shall always be 1Hz (i.e. regardless of the selected output rate).

The configured measurement string shall be output in response to a measurement request ("`<network node address>`") from the user.

e.g. Q (where Q is the default MaxiMet identifier, range A-Z).

When the user issues a poll measurement request, the last computed set of 1 Hz measurement shall be output.

Response time to a poll shall be less than 570 milliseconds but note that parameters that require GPS may not be readily available until satellite fix has been achieved.

## 6.4. Configuring MaxiMet for SDI-12

To configure a MaxiMet unit for SDI-12:

Connect a default set MaxiMet to a PC as described in Para 4.6.

Open MetSet as described on Para 6.2.

Click on the Edit Comms page and select:-

Set Protocol for SDI-12. and

Set Interface for SDI-12.

No other settings changes are required.

Click on Save Settings to Device on the Online Mode Menu.

Shut down the MaxiMet unit.

Change the hardware connections for SDI-12 (see Para 4.9).

Power up the MaxiMet unit (**SDI-12 supply voltage 9.6v to 16v dc**).

Notes:-

When Protocol is set for SDI-12 mode it automatically sets the MaxiMet Baud rate to 1200 baud irrespective of its Baud Setting.

Only parameters mentioned below are available in Protocol SDI-12 mode irrespective of the Reporting page setting.

### 6.4.1 SDI-12 Units of Measure

#### NOTE

**Not all the following outputs are available and will depend on the MaxiMet variant, see page 6, Para 2.1.2.**

GMX Model SDI-12 Output Parameters.

Relative Wind Speed:	Metres/Second.
Corrected Wind Speed:	Metres/Second.
Relative Wind Direction:	Degrees
Corrected Wind Direction:	Degrees
Temperature:	Degrees C
Relative Humidity:	%
dewpoint:	Degrees C
pressure:	Hecto Pascals
precipitation intensity:	mm/h
total precipitation:	mm
solar radiation:	W/m <sup>2</sup>
sunshine hours:	h
height above sea level:	m
latitude:	degrees (positive values are N, negative are S)
longitude:	degrees (positive values are E, negative are W)
date:	yyyymmdd
time:	hhmmss
Status	4 Digit Sensor Status code (e.g. 0000 for a no fault condition)

## 6.4.2 SDI-12 Commands

Note: Unavailable measurements shall be "padded", e.g.: +999.99.

?!	Returns Unit Address (default is 0).
a	Current unit address letter (factory default is 0, range is 0 to 9).
b	New address letter, range 0 to 9.
aAb!	Change unit address from a to b see above.
aM!	Address, Relative Wind Direction, Relative Wind Speed, Corrected Wind Direction, Corrected Wind Speed (GPS option units only), Status.
aM1!	Address, Temperature, Relative Humidity, Dewpoint, Pressure and Status.
aM2!	Address, Relative Wind Direction, Relative Wind Speed and Status.
aM3!	Address, Precipitation Intensity (Rain), Total Precipitation (Rain), Status.
aM4!	Address, Solar Radiation, Sunshine Hours, Status.
aM5!	Address, signed Latitude integer part, signed Latitude fractional part, signed Longitude integer part, signed Longitude fractional part, Height above mean sea level, Status and CRC.
AM6!	Address, Year, Month, Day, Hour, Minute, Second and Status.
aD0!	Request a line of the above data.

Command	Description	Response	Example
?!	Unit Address	a<CR><LF>	0<CR><LF>
<b>aAb!</b>	Change the unit address a = 0, the default. b = the new address.	b<CR><LF>	1<CR><LF>
<b>al!</b>	Unit Identification	013GillInst Serial Number<CR><LF>	013GillInst 00014490002<CR><LF>
<b>aM!</b>	Address, Relative Wind Direction, Relative Wind Speed, Corrected Wind Direction, Corrected Wind Speed (GPS option unit only), Status.	atttn<CR><LF> a is unit identifier. t is time in seconds. n is number of data values. Measurement command to retrieve a reading of the maximum time the MaxiMet will take to complete a measurement, have data ready and the number of data values.	00035<CR><LF> 0 is unit identifier. 003 is 3 sec. measurement. 5 is the number of data readings (Direction, Speed, Corrected Direction and Corrected Speed).
aD0!	Retrieve a line of the above data.	<address><relative wind direction><relative wind speed><corrected wind direction><corrected wind speed><status>CR><LF>	0+220+000.01+218+999.99 +0000<CR><LF>
<b>aM1!</b>	Address, Temperature, Relative Humidity, Dewpoint, Pressure and Status	atttn<CR><LF>	00025<CR><LF>
aD0!	Retrieve a line of the above data.	<address><temperature> <relative humidity><dewpoint> <pressure><status> CR><LF	0+024.3+036+008.4 +1024.9+0000<CR><LF>

<b>aM2!</b>	Address, Relative Wind Direction, Relative Wind Speed and Status.	attn<CR><LF>	00033<CR><LF>
aD0!	Retrieve a line of the above data.	a<dir><mag><status><CR><LF>	0+029+000.01+0000<CR><LF>
<b>aM3!</b>	Address, Precipitation Intensity, Total precipitation, Status	attn<CR><LF>	00033<CR><LF>
aD0!	Retrieve a line of the above data.	<address><precipitation intensity><total precipitation><status><CR><LF>	0+002.1+123.1+0000<CR><LF>
<b>aM4!</b>	Address, Solar Radiation, Sunshine Hours, Status	< attn<CR><LF>	00023<CR><LF>
aD0!	Retrieve a line of the above data.	address><solar radiation><sunshine hours><status	0+0001+00.00+0000<CR><LF>
<b>aM5!</b>	Address, signed latitude integer part, signed latitude fractional part, signed longitude integer part, signed longitude fractional part, height above mean sea level, status.	< attn<CR><LF>	00026<CR><LF>
aD0!	Retrieve a line of the above data.	<address><signed latitude integer part><signed latitude fractional part><signed longitude integer part><signed longitude fractional part><height above mean sea level><status> <CR><LF>	0+50+763052-001-539920+00000.90+0000<CR><LF>
<b>aM6!</b>	Address, Year, Month, Day, Hour, Minute, Second, Status	< attn<CR><LF>	00017<CR><LF>
aD0!	Retrieve a line of the above data.	<address><Year><Month><Day><Hour><Minute><Second><status><CR><LF>	0+2015+06+15+14+07+52+0000<CR><LF>

### 6.4.3 SDI-12 Commands with CRC

Note: Unavailable measurements shall be "padded", e.g.: +999.99.

- ?! Returns Unit Address (default is 0).
- a Current unit address letter (factory default is 0, range is 0 to 9).
- b New address letter, range 0 to 9.
- aAb! Change unit address from a to b see above.
- aMC! Address, Relative Wind Direction, Relative Wind Speed, Corrected Wind Direction, Corrected Wind Speed (If GPS fitted), Status and CRC.
- aMC1! Address, Temperature, Relative Humidity, Dewpoint, Pressure, Status and CRC (GMX600).
- aM2C! Address, Relative Wind Direction, Relative Wind Speed Status and CRC.
- aM3C Address, Precipitation Intensity, Total Precipitation, Status and CRC.
- aMC4! Address, Solar Radiation, Sunshine Hours, Status and CRC.
- aMC5! Address, signed Latitude integer part, signed Latitude fractional part, signed Longitude integer part, signed Longitude fractional part, Height above mean sea level, Status and CRC.
- AMC6! Address, Year, Month, Day, Hour, Minute, Second, Status and CRC.
- aD0 Request a line of the above data.

Command	Description	Response	Example
<b>aMC!</b>	Address, Relative Wind Direction, Relative Wind Speed, Corrected Wind Direction, Corrected Wind Speed (GPS option unit only), Status and CRC.	attn<CR><LF> a is unit identifier. ttt is time in seconds. n is number of data values. Measurement command to retrieve a reading of the maximum time the MaxiMet will take to complete a measurement, have data ready and the number of data values.	00035<CRC><CR><LF> 0 is unit identifier. 003 is 3 sec. measurement. 5 is the number of data readings (Direction, Speed, Corrected Direction, Corrected Speed and Status).
aD0!	Retrieve a line of the above data.	<address><relative wind direction><relative wind speed><corrected wind direction><corrected wind speed><status><CRC><CR><LF>	0+192+000.07+267+999.9+0000DQ^<CR><LF>
<b>aMC1!</b>	Address, Temperature, Relative Humidity, Dewpoint, Pressure, Status and CRC.	attn<CR><LF>	00025<CRC><CR><LF>
aD0!	Retrieve a line of the above data.	<address><temperature><relative humidity><dewpoint><pressure><status><CRC><CR><LF>	0+023.3+035+007.2+1015.1+0000AiL<CR><LF>
<b>aMC2!</b>	Address, Relative Wind Direction, Relative Wind Speed, Status and CRC.	attn<CR><LF>	00033<CRC><CR><LF>
aD0!	Retrieve a line of the above data.	a<dir><mag><status><CRC><CR><LF>	0+168+000.02+0000GbT><CR><LF>

<b>aMC3!</b>	Address, Precipitation Intensity, Total Precipitation, Status and CRC.	attn<CR><LF>	00033<CRC><CR><LF>
aD0!	Retrieve a line of the above data.	<address><precipitation intensity><total precipitation><status><CRC><CR><LF>	0+000.0+000.0+0000HB@<CR><LF>
<b>aMC4!</b>	Address, Solar Radiation, Sunshine Hours, Status and CRC	< attn<CR><LF>	00023<CRC><CR><LF>
aD0!	Retrieve a line of the above data.	address><solar radiation><sunshine hours><status	0+0001+00.00+0000HB@<CR><LF>
<b>aMC5!</b>	Address, Longitude, Latitude, Height, Status and CRC	< attn<CR><LF>	00026<CRC><CR><LF>
aD0!	Retrieve a line of the above data.	<address><signed latitude integer part><signed latitude fractional part><signed longitude integer part><signed longitude fractional part><height above mean sea level><status>CRC>CR><LF	0+50+763052-001-539920+00000.90+0000 HB@<CR><LF>
<b>aMC6!</b>	Address, Year, Month, Day, Hour, Minute, Second, Status and CRC	< attn<CR><LF>	00017<CRC><CR><LF>
aD0!	Retrieve a line of the above data.	<address><Year><Month><Day><Hour><Minute><Second><status><CRC><CR><LF>	0+2015+06+15+14+07+52+0004<CR><LF>

## 6.5. Configuring MaxiMet for MODBUS

### 6.5.1 MaxiMet Supported Modbus Specification

MODBUS	RTU or ASCII.
Baud Rate	9600 or 19200 Baud.
COMMS	RS232 point to point only, RS485 2 wire networkable.
Modbus Parameters	ASCII or RTU.

Parameter	Modbus ASCII	Modbus RTU
Character	ASCII 0 to 9 and A to F (Hex)	Binary 0 to 255
Error Check	Longitudinal Redundancy Check (LRC)	Cyclic Redundancy Check (CRC)
Frame Start	Character ':' (3A Hex)	3.5 Characters Silence
Frame End	Characters CR/LF (0D/0A Hex)	3.5 Characters Silence
Gaps in Message	1 Second	1.5 Times Character Length
Start Bit	1	1
Data Bits	7	8
Parity	Even/Odd	Even/Odd
Stop Bits	1	2

Read Holding Registers function code is 0x03.

Diagnostics 0x08.

Get Comm event counter 0x0B.

Report slave/server ID 0x11.

#### Requires:-

MaxiMet.

MetSet Software.

Connect a MaxiMet to a PC COM port (default communication is RS232).

Open Gill MetSet Software.

Click on Connect and Read to reach the Editing Pages as shown below.

#### Configuration

#### Click on the MODBUS Page

Mode:	Choose between RTU and ASCII, in this case RTU.
Address:	Choose a MaxiMet Address number between 1 to 247.
Data Bits:	Choose 7 for Modbus ASCII and 8 for Modbus RTU.
Stop Bits:	Choose 1 for Even/Odd Parity or 2 for No Parity (None).
Parity:	Choose Even/Odd or None.
Termination Char ASCII code:	Choose between 0-255.
Inter Char Timeout (ms):	Choose between 500ms to 10000ms.

The screenshot shows the 'ASCII\_Setup' tab in the MetSet software. The configuration parameters are as follows:

- Mode: RTU
- Address: 1
- Data bits: 8
- Stop bits: 2
- Parity: NONE
- Termination Char ASCII code: 10
- Inter-char timeout (ms): 1000

### Select the COMMS Page

Protocol:	Default is Gill.	Select MODBUS
Interface:	Default is RS232.	Select RS232 or RS4852W.
RS232 will only allow a single point to point non multi drop network connection. RS485 2 wire will allow networking with up to 32 connected devices.		
Baud Rate:	Default is 19200.	Select required Baud rate (9600 or 19200 supported).
Node ID:	Default is Q.	Not used for MODBUS.
Output Rate:	Default is 1Hz.	Set update rate for MaxiMet Data
Message Mode:	Default is CONT.	Ensure that the setting is CONT mode, Message Mode POLL is not applicable for Modbus use.

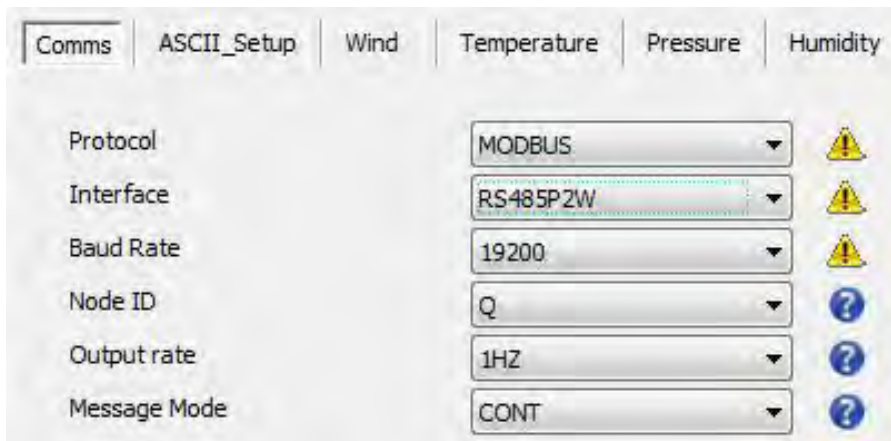

When required settings have been selected click on Save Settings to Device

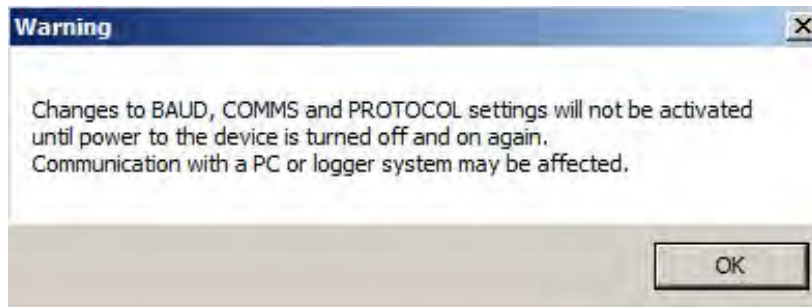

Click on Yes and OK.

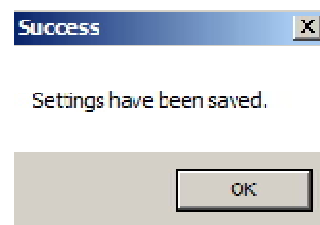

Power down the MaxiMet and apply power back to the MaxiMet to complete setting changes.

**Note:** now that the unit is in MODBUS mode if any further changes need to be made use the SAFE MODE connection and method to re-establish communication with MetSet (See Para 6.7).

**MaxiMet MODBUS NOTES****1. Summary of Modbus Output Parameters**

Start with MaxiMet in Gill ASCII mode and use MetSet to configure which parameters are to be output and the exact order in which they are to be output before setting the unit for ModBus communication.

Then refer to the Modbus Output parameter table below to determine how many registers each chosen parameter will take up.

Then, in the order in which the parameters will be output, set up the user Modbus register table starting at 400001 with the required output parameters.

Output Parameter	Type	No. of Registers
NODE	4-byte character string	2
SPEED	32 Bit Floating point value	2
CORRECTED SPEED	32 Bit Floating point value	2
GUST SPEED	32 Bit Floating point value	2
CORRECTED GUST SPEED	32 Bit Floating point value	2
AVERAGE SPEED	32 Bit Floating point value	2
AVERAGE CORRECTED SPEED	32 Bit Floating point value	2
DIRECTION	32 Bit Floating point value	2
CORRECTED DIRECTION	32 Bit Floating point value	2
GUST DIRECTION	32 Bit Floating point value	2
CORRECTED GUST DIRECTION	32 Bit Floating point value	2
AVERAGE DIRECTION	32 Bit Floating point value	2
AVERAGE CORRECTED DIRECTION	32 Bit Floating point value	2
PRESSURE	32 Bit Floating point value	2
PRESSURE AT SEA LEVEL	32 Bit Floating point value	2
PRESSURE AT STATION	32 Bit Floating point value	2
RELATIVE HUMIDITY	32 Bit Floating point value	2
ABSOLUTE HUMIDITY	32 Bit Floating point value	2
TEMPERATURE	32 Bit Floating point value	2
DEWPOINT	32 Bit Floating point value	2
PRECIPITATION TOTAL	32 Bit Floating point value	2
PRECIPITATION INTENSITY	32 Bit Floating point value	2
PRECIPITATION STATUS	4-byte character string	2
SOLAR RADIATION	32 Bit Floating point value	2
SOLAR HOURS	32 Bit Floating point value	2
COMPASS HEADING	32 Bit Floating point value	2
GPS HEADING	32 Bit Floating point value	2
GPS SPEED OVER GROUND	32 Bit Floating point value	2
GPS LOCATION (Longitude)	32 Bit Floating point value	2
GPS LOCATION (Latitude)	32 Bit Floating point value	2
GPS LOCATION (Height)	32 Bit Floating point value	2
GPS STATUS (Fix/no. of satellites)	4-byte character string	2
DATE	16 Byte Character String	8
TIME (from Date)	16 Byte Character String	8
SUPPLY VOLTAGE	32 Bit Floating point value	2
STATUS	32 bit Unsigned Integer (UINT)	2
WINDSTAT	32 bit Unsigned Integer (UINT)	2

2. All registers are 16bit.
3. The first byte is high order and the second is low.
4. Each measurement is comprised of two 16bit registers.
5. For all registers, the order of the two data bytes comprising the 16-bit register's value shall be: High Byte/Low Byte.
6. For each 32-bit data type (whether floating point or integer), the order of the first pair of bytes and last pair of bytes shall be: High Word/Low Word.
7. Registers start at address 40001.
8. Holding registers available in the order of the MaxiMet data string (which can be established by the REPORT command in non-Modbus Gill ASCII Mode).
9. If measurements cannot be computed (i.e. a blank field in Gill mode output string), their Holding Register contents shall be set to the Maximum Positive value (0x7FFFFFFF for 32-bit format data (both floating point and integer), and as 0x7FFF for 16-bit format data).

GMX100 MODBUS Default Setting Register Table.

Register Type	Register Numbers	Value Type
4ch string	40001-02	Node
32bit float	40003-04	Precipitation Total
32bit float	40005-06	Precipitation Intensity
16ch string	40007-14	Date
16ch string	40015-22	Time
32bit float	40023-24	Supply Voltage
32bit UINT	40025-26	Status

GMX200 MODBUS Default Setting Register Table.

Register Type	Register Numbers	Value Type
4ch string	40001-02	Node
32bit float	40003-04	Direction
32bit float	40005-06	Speed
32bit float	40007-08	CDIR
16ch string	40009-16	Date
16ch string	40017-24	Time
32bit float	40025-26	Supply Voltage
32bit UINT	40027-28	Status

GMX200 with GPS MODBUS Default Setting Register Table.

Register Type	Register Numbers	Value Type
4ch string	40001-02	Node
32bit float	40003-04	Direction
32bit float	40005-06	Speed
32bit float	40007-08	Corrected Direction
32 bit float	40009-10	Corrected Speed
32 bit float	40011-12	GPS Latitude
32 bit float	40013-14	GPS Longitude
32 bit float	40015-16	GPS Height
16ch string	40017-24	Date
16ch string	40025-32	Time
32bit float	40033-34	Supply Voltage
32bit UINT	40035-36	Status

GMX300 MODBUS Default Setting Register Table.

Register Type	Register Numbers	Value Type
4ch string	40001-02	Node
32bit float	40003-04	Pressure
32bit float	40005-06	Relative Humidity
32bit float	40007-08	Temperature
32bit float	40009-10	Dew point
16ch string	40011-18	Date
16ch string	40019-26	Time
32bit float	40027-28	Supply Voltage
32bit UINT	40029-30	Status

GMX301 MODBUS Default Setting Register Table:

Register Type	Register Numbers	Value Type
4ch string	40001-02	Node
32bit float	40003-04	Pressure
32bit float	40005-06	Relative Humidity
32bit float	40007-08	Temperature
32bit float	40009-10	Dew point
32bit float	40011-12	Solar Radiation
16ch string	40013-20	Date
16ch string	40021-28	Time
32bit float	40029-30	Supply Voltage
32bit UINT	40031-32	Status

GMX400 MODBUS Default Setting Register Table:

Register Type	Register Numbers	Value Type
4ch string	40001-02	Node
32bit float	40003-04	Pressure
32bit float	40005-06	Relative Humidity
32bit float	40007-08	Temperature
32bit float	40009-10	Dew point
32bit float	40011-12	Precipitation Total
32bit float	40013-14	Precipitation Intensity
16ch string	40015-22	Date
16ch string	40023-30	Time
32bit float	40031-32	Supply Voltage
32bit UINT	40033-34	Status

GMX500 MODBUS Default Setting Register Table:

Register Type	Register Numbers	Value Type
4ch string	40001-02	Node
32bit float	40003-04	Direction
32bit float	40005-06	Speed
32bit float	40007-08	Corrected Direction
32bit float	40009-10	Pressure
32bit float	40011-12	Relative Humidity
32bit float	40013-14	Temperature
32bit float	40015-16	Dew point
16ch string	40017-24	Date
16ch string	40025-32	Time
32bit float	40033-34	Supply Voltage
32bit UINT	40035-36	Status

GMX500 with GPS MODBUS Default Setting Register Table:

Register Type	Register Numbers	Value Type
4ch string	40001-02	Node
32bit float	40003-04	Direction
32bit float	40005-06	Speed
32bit float	40007-08	Corrected Direction
32bit float	40009-10	Corrected Speed
32bit float	40011-12	Pressure
32bit float	40013-14	Relative Humidity
32bit float	40015-16	Temperature
32bit float	40017-18	Dew point
32bit float	40019-20	GPS Latitude
32bit float	40021-22	GPS longitude
32bit float	40023-24	GPS Height
16ch string	40025-32	Date
16ch string	40033-40	Time
32bit float	40041-42	Supply Voltage
32bit UINT	40043-44	Status

GMX501 MODBUS Default Setting Register Table:

Register Type	Register Numbers	Value Type
4ch string	40001-02	Node
32bit float	40003-04	Direction
32bit float	40005-06	Speed
32bit float	40007-08	Corrected Direction
32bit float	40009-10	Pressure
32bit float	40011-12	Relative Humidity
32bit float	40013-14	Temperature
32bit float	40015-16	Dew point
32bit float	40017-18	Solar Radiation
16ch string	40019-26	Date
16ch string	40027-32	Time
32bit float	40033-34	Supply Voltage
32bit UINT	40035-36	Status

GMX501 with GPS MODBUS Default Setting Register Table:

Register Type	Register Numbers	Value Type
4ch string	40001-02	Node
32bit float	40003-04	Direction
32bit float	40005-06	Speed
32bit float	40007-08	Corrected Direction
32bit float	40009-10	Corrected Speed
32bit float	40011-12	Pressure
32bit float	40013-14	Relative Humidity
32bit float	40015-16	Temperature
32bit float	40017-18	Dew point
32bit float	40019-20	Solar Radiation
32 bit float	40021-22	GPS Latitude
32 bit float	40023-24	GPS longitude
32 bit float	40025-26	GPS Height
16ch string	40027-34	Date
16ch string	40035-42	Time
32bit float	40043-44	Supply Voltage
32bit UINT	40045-46	Status

GMX600 MODBUS Default Setting Register Table:

Register Type	Register Numbers	Value Type
4ch string	40001-02	Node
32bit float	40003-04	Direction
32bit float	40005-06	Speed
32bit float	40007-08	Corrected Direction
32bit float	40009-10	Pressure
32bit float	40011-12	Relative Humidity
32bit float	40013-14	Temperature
32bit float	40015-16	Dew point
32bit float	40017-18	Precipitation Total
32bit float	40019-20	Precipitation Intensity
16ch string	40021-28	Date
16ch string	40029-36	Time
32bit float	40037-38	Supply Voltage
32bit UINT	40039-40	Status

See Simply Modbus program reading example MaxiMet GMX 600 MODBUS Data as follows:-

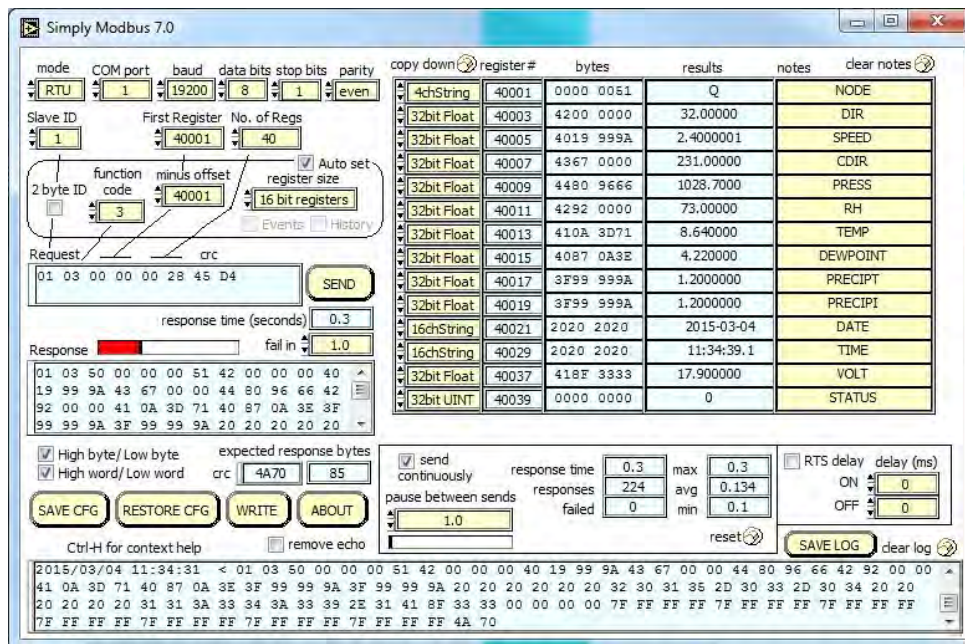

---

**GMX600 with GPS MODBUS Default Setting Register Table:**

<b>Register Type</b>	<b>Register Numbers</b>	<b>Value Type</b>
4ch string	40001-02	Node
32bit float	40003-04	Direction
32bit float	40005-06	Speed
32bit float	40007-08	Corrected Direction
32bit float	40009-10	Corrected Speed
32bit float	40011-12	Pressure
32bit float	40013-14	Relative Humidity
32bit float	40015-16	Temperature
32bit float	40017-18	Dew point
32bit float	40019-20	Precipitation Total
32bit float	40021-22	Precipitation Intensity
32bit float	40023-24	GPS Latitude
32bit float	40025-26	GPS Longitude
32bit float	40027-28	GPS Height
16ch string	40029-36	Date
16ch string	40037-44	Time
32bit float	40045-46	Supply Voltage
32bit UINT	40047-48	Status

## 6.6. Configuring MaxiMet for NMEA Output

Connect a default set MaxiMet to a PC as described in Para 4.6.

Open MetSet as described on Para 6.2 and click on the Reporting page.

Change the Report Format drop down menu from USERDEF to NMEA.

On the Comms Page select the required Interface, generally RS422.

On the Comms Page Select the required Baud rate, normally 4800 bauds (or sometimes 9600 baud).

Click on Save Settings to Device.

**NOTE:** Wind Speed units are fixed at Knots (N) irrespective of how wind readings units have been set up on the MetSet Wind Page. The same applies for GPS settings, readings are always in knots in NMEA mode.

### 6.6.1 GMX100 NMEA Output String

"\$WIXDR,Y,000.0,M,PRECIP\*01<CR><LF>"

Where:-

\$WIXDR	Wind Instrument Transducer
Y	Type of Sensor (Precipitation)
000.0	Millimetres per hour of Precipitation
M	Precipitation Units of Measure (Millimetres)
PRECIP	Name of Precipitation Sensor
*01	Hex CheckSum

<CR> is a Carriage return character (ASCII hex value d)

<LF> is a Line Feed Character (ASCII hex value a)

Checksum, the 2 digit Hex Checksum sum figure is calculated from the Exclusive OR of the bytes between (and not including) the \$ and \* characters.

Example GMX100 data string.

\$WIXDR,Y,000.0,M,PRECIP\*01

Repeated every second (1Hz output).

## 6.6.2 GMX200 NMEA Output String

\$WIMWV,049,R,000.03,N,A\*03<CR><LF>.

Where:-

\$WIMWV	Wind Instrument Mean Wind direction and Velocity.
049	Wind Direction.
R	Relative Wind measurement, wind speed and/or direction information, reported with respect to the MaxiMet North marker.
000.03	Wind Speed.
N	Knots (NMEA output fixed to Knots measurement only).
A	Acceptable measurement (V is a void fail measurement).
03	Hex Check Sum.

Immediately followed by:-

\$WIMWV,049,T,,N,A\*18<CR><LF>.

\$WIMWV	Wind Instrument Mean Wind direction and Velocity.
049	Wind Direction.
T	True Wind measurement, wind speed and/or direction information, corrected by a compass and GPS (option) to give accurate data regardless of where north marker is aligned.
,,	Wind Speed only available if a GPS option is fitted (format e.g. 001.05).
N	Knots (NMEA output fixed to Knots measurement only).
A	Acceptable measurement (V is a void fail measurement).
18	Hex Check Sum.

Immediately followed by GPS data if option available.

\$GPGGA,161229.487,3723.2475,N,12158.3416,W,1,07,1.0,9.0,M, , , ,0000\*18<CR><LF>.

Where

\$GPGGA	NMEA GPS Protocol Header
161229.487	UTC Time, hhmmss.sss
3723.2475	Latitude ddm. mmmm
N	North/South Indicator
12158.3416	Longitude ddm. mmmm
W	East/West indicator
1	Position Fix Indicator (See below)
07	Satellites being used (Range 0-12)
1.0	Horizontal Dilution of Precision
9.0	Mean Sea Level (NSL) Altitude in Metres
M	MSL Units, Metres
, , , ,	Geoid Separation and Units in Metres
0000	Differential GPS Reference Station ID.
*18	Checksum

Position Fix Indicator:

Value	Description
0	Fix not available or invalid
1	GPS SPS Mode, fix valid
2	Differential GPS, SPS Mode, fix valid
3-5	Not supported
6	Dead Reckoning Mode, fix valid

Example GMX200 NMEA Data String.

\$WIMWV,069,R,004.06,N,A\*00

\$WIMWV,122,T,,N,A\*14

\$GPGGA,161229.487,3723.2475,N,12158.3416,W,1,07,1.0,9.0,M, , , ,0000\*18 (GPS only).

Repeated every second (1Hz output).

### 6.6.3 GMX300 NMEA Output String

\$WIXDR,C,+023.9,C,TEMP,P,1.0243,B,PRESS,H,039,P,RH,\*01<CR><LF>.

Where: -

\$WIXDR	Wind Instrument Transducer
C	Type of Sensor (Temperature)
+023.9	Temperature Reading
C	Temperature Reading in Degrees Centigrade
TEMP	Name of Temperature Sensor
P	Type of Sensor (Pressure)
1.0243	Pressure Reading in Bars.
B	Pressure Units of Measure (Bars)
PRESS	Name of Pressure Sensor
H	Type of Sensor (Humidity)
039	Humidity Reading in Percent
P	Humidity Units of Measure (Percent)
RH	Name of Relative Humidity Sensor
*01	Hex CheckSum

<CR> is a Carriage return character (ASCII hex value d)

<LF> is a Line Feed Character (ASCII hex value a)

Checksum, the 2 digit Hex Checksum sum figure is calculated from the Exclusive OR of the bytes between (and not including) the \$ and \* characters.

Example GMX300 NMEA Data String.

\$WIXDR,C,+023.2,C,TEMP,P,1.0281,B,PRESS,H,037,P,RH,\*0A

Repeated every second (1Hz output).

### 6.6.4 GMX301 NMEA Output String.

\$WIXDR,C,+023.9,C,TEMP,P,1.0243,B,PRESS,H,039,P,RH,Z,0000,W,SOLAR\*01<CR><LF>.

Where: -

\$WIXDR	Wind Instrument Transducer
C	Type of Sensor (Temperature)
+023.9	Temperature Reading
C	Temperature Reading in Degrees Centigrade
TEMP	Name of Temperature Sensor
P	Type of Sensor (Pressure)
1.0243	Pressure Reading in Bars.
B	Pressure Units of Measure (Bars)
PRESS	Name of Pressure Sensor
H	Type of Sensor (Humidity)
039	Humidity Reading in Percent
P	Humidity Units of Measure (Percent)
RH	Name of Relative Humidity Sensor
Z	Type of Sensor (Solar)
0000	Solar Radiation reading in W/M <sup>2</sup>
W	Solar Units of Measure (Total W/M <sup>2</sup> )
SOLAR	Name of Solar Sensor
*01	Hex CheckSum

<CR> is a Carriage return character (ASCII hex value d)

<LF> is a Line Feed Character (ASCII hex value a)

Checksum, the 2 digit Hex Checksum sum figure is calculated from the Exclusive OR of the bytes between (and not including) the \$ and \* characters.

Example GMX301 NMEA Data String.

\$WIXDR,C,+023.9,C,TEMP,P,1.0243,B,PRESS,H,039,P,RH,Z,0000,W,SOLAR\*01<CR><LF>.

Repeated every second (1Hz output).

## 6.6.5 GMX400 NMEA Output String

\$WIXDR,C,+023.9,C,TEMP,P,1.0243,B,PRESS,H,039,P,RH,Y,000.0,M,PRECIP\*01<CR><LF>.

Where: -

\$WIXDR	Wind Instrument Cross Transducer
C	Type of Sensor (Temperature)
+023.9	Temperature Reading
C	Temperature Reading in Degrees Centigrade
TEMP	Name of Temperature Sensor
P	Type of Sensor (Pressure)
1.0243	Pressure Reading in Bars.
B	Pressure Units of Measure (Bars)
PRESS	Name of Pressure Sensor
H	Type of Sensor (Humidity)
039	Humidity Reading in Percent
P	Humidity Units of Measure (Percent)
RH	Name of Relative Humidity Sensor
Y	Type of Sensor (Precipitation)
000.0	Millimetres per hour of Precipitation
M	Precipitation Units of Measure (Millimetres)
PRECIP	Name of Precipitation Sensor
*01	Hex CheckSum

<CR> is a Carriage return character (ASCII hex value d)

<LF> is a Line Feed Character (ASCII hex value a)

Checksum, the 2 digit Hex Checksum sum figure is calculated from the Exclusive OR of the bytes between (and not including) the \$ and \* characters.

Example GMX 400 Data.

\$WIXDR,C,+023.2,C,TEMP,P,1.0281,B,PRESS,H,037,P,RH,Y,000.0,M,PRECIP\*0A

Repeated every second (1Hz output).

## 6.6.6 GMX500 NMEA Output String

\$WIMWV,049,R,000.03,N,A\*03<CR><LF>. Where:-

\$WIMWV	Wind Instrument Mean Wind direction and Velocity.
049	Wind Direction.
R	Relative Wind measurement, wind speed and/or direction information, reported with respect to the MaxiMet North marker.
000.03	Wind Speed.
N	Knots (NMEA output fixed to Knots measurement only).
A	Acceptable measurement (V is a void fail measurement).
03	Hex Check Sum.

Immediately followed by:-

\$WIMWV,049,T,,N,A\*18<CR><LF>.

\$WIMWV	Wind Instrument Mean Wind direction and Velocity.
049	Wind Direction.
T	True Wind measurement, wind speed and/or direction information, corrected by a compass and GPS (option) to give accurate data regardless of where north marker is aligned.
,,	Wind Speed only available if a GPS option is fitted.
N	Knots (NMEA output fixed to Knots measurement only).
A	Acceptable measurement (V is a void fail measurement).
18	Hex Check Sum.

Immediately followed by:-

```
$WIXDR,C,+023.9,C,TEMP,P,1.0243,B,PRESS,H,039,P,RH,*01<CR><LF>.
```

Where: -

\$WIXDR	Wind Instrument Transducer
C	Type of Sensor (Temperature)
+023.9	Temperature Reading
C	Temperature Reading in Degrees Centigrade
TEMP	Name of Temperature Sensor
P	Type of Sensor (Pressure)
1.0243	Pressure Reading in Bars.
B	Pressure Units of Measure (Bars)
PRESS	Name of Pressure Sensor
H	Type of Sensor (Humidity)
039	Humidity Reading in Percent
P	Humidity Units of Measure (Percent)
RH	Name of Relative Humidity Sensor
*01	Hex CheckSum

Followed by GPS data if option available.

```
$GPGGA,161229.487,3723.2475,N,12158.3416,W,1,07,1.0,9.0,M, , , ,0000*18<CR><LF>.
```

Where

\$GPGGA	NMEA GPS Protocol Header
161229.487	UTC Time, hhmmss.sss
3723.2475	Latitude ddmm.mmmm
N	North/South Indicator
12158.3416	Longitude ddmm.mmmm
W	East/West indicator
1	Position Fix Indicator (See below)
07	Satellites being used (Range 0-12)
1.0	Horizontal Dilution of Precision
9.0	Mean Sea Level (NSL) Altitude in Metres
M	MSL Units, Metres
, , , ,	Geoid Separation and Units in Metres
0000	Differential GPS Reference Station ID.
*18	Checksum

<CR> is a Carriage return character (ASCII hex value d)

<LF> is a Line Feed Character (ASCII hex value a)

Checksum, the 2 digit Hex Checksum sum figure is calculated from the Exclusive OR of the bytes between (and not including) the \$ and \* characters.

Example GMX500 NMEA Data String.

```
$WIMWV,069,R,004.06,N,A*00
```

```
$WIMWV,122,T,,N,A*14
```

```
$WIXDR,C,+023.2,C,TEMP,P,1.0281,B,PRESS,H,037,P,RH,*0A
```

```
$GPGGA,161229.487,3723.2475,N,12158.3416,W,1,07,1.0,9.0,M, , , ,0000*18<CR><LF> (GPS unit).
```

Repeated every second (1Hz output).

## 6.6.7 GMX501 NMEA output String

\$WIMWV,049,R,000.03,N,A\*03<CR><LF>. Where:-

\$WIMWV	Wind Instrument Mean Wind direction and Velocity.
049	Wind Direction.
R	Relative Wind measurement, wind speed and/or direction information, reported with respect to the MaxiMet North marker.
000.03	Wind Speed.
N	Knots (NMEA output fixed to Knots measurement only).
A	Acceptable measurement (V is a void fail measurement).
03	Hex Check Sum.

Immediately followed by:-

\$WIMWV,185,T,000.19,N,A\*0F  
<CR><LF>.

\$WIMWV	Wind Instrument Mean Wind direction and Velocity.
185	Wind Direction.
T	True Wind measurement, wind speed and/or direction information, corrected by a compass and GPS (option) to give accurate data regardless of where north marker is aligned.
000.19	Wind Speed only available if a GPS option is fitted (,, if no GPS).
N	Knots (NMEA output fixed to Knots measurement only).
A	Acceptable measurement (V is a void fail measurement).
0F	Hex Check Sum.

Immediately followed by:-

\$WIXDR,C,+023.9,C,TEMP,P,1.0243,B,PRESS,H,039,P,RH,Z,0000,W,SOLAR\*01<CR><LF>.

Where: -

\$WIXDR	Wind Instrument Cross Transducer
C	Type of Sensor (Temperature)
+023.9	Temperature Reading
C	Temperature Reading in Degrees Centigrade
TEMP	Name of Temperature Sensor
P	Type of Sensor (Pressure)
1.0243	Pressure Reading in Bars.
B	Pressure Units of Measure (Bars)
PRESS	Name of Pressure Sensor
H	Type of Sensor (Humidity)
039	Humidity Reading in Percent
P	Humidity Units of Measure (Percent)
RH	Name of Relative Humidity Sensor
Z	Type of Sensor (Solar)
0000	Solar Radiation reading in W/M <sup>2</sup>
W	Solar Units of Measure (Total W/M <sup>2</sup> )
SOLAR	Name of Solar Sensor
*01	Hex CheckSum

Followed by GPS data if option available.

\$GPGGA,080552.000,5045.7752,N,00132.3963,W,1,08,1.0,10.2,M,47.8,M,,0000\*79<CR><LF>.

Where

\$GPGGA	NMEA GPS Protocol Header
080552.000	UTC Time, hhmmss.sss
5045.7752	Latitude ddmm.mmmm
N	North/South Indicator

00132.3963	Longitude ddm. mmmm
W	East/West indicator
1	Position Fix Indicator (See below)
08	Satellites being used (Range 0-12)
1.0	Horizontal Dilution of Precision
10.2	Mean Sea Level (NSL) Altitude in Metres
M	MSL Units, Metres
47.8	Geoid Separation in Metres
M	Geoid Units, Metres.
,,	No reading.
0000	Differential GPS Reference Station ID.
*79	Checksum

<CR> is a Carriage return character (ASCII hex value d)

<LF> is a Line Feed Character (ASCII hex value a)

Checksum, the 2 digit Hex Checksum sum figure is calculated from the Exclusive OR of the bytes between (and not including) the \$ and \* characters.

Example GMX501 Data.

```
$WIMWV,069,R,004.06,N,A*00
```

```
$WIMWV,122,T,,N,A*14
```

```
$WIXDR,C,+023.2,C,TEMP,P,1.0281,B,PRESS,H,037,P,RH,Z,0000,W,SOLAR*0A
```

```
$GPGGA,080552.000,5045.7752,N,00132.3963,W,1,08,1.0,10.2,M,47.8,M,,0000*79<CR><LF>
```

(GPS unit).

Repeated every second (1Hz output).

## 6.6.8 GMX600 NMEA Output String

\$WIMWV,049,R,000.03,N,A\*03<CR><LF>. Where:-

\$WIMWV	Wind Instrument Mean Wind direction and Velocity.
049	Wind Direction.
R	Relative Wind measurement, wind speed and/or direction information, reported with respect to the MaxiMet North marker.
000.03	Wind Speed.
N	Knots (NMEA output fixed to Knots measurement only).
A	Acceptable measurement (V is a void fail measurement).
03	Hex Check Sum.

Immediately followed by:-

\$WIMWV,049,T,,N,A\*18<CR><LF>.

\$WIMWV	Wind Instrument Mean Wind direction and Velocity.
049	Wind Direction.
T	True Wind measurement, wind speed and/or direction information, corrected by a compass and GPS (option) to give accurate data regardless of where north marker is aligned.
,,	Wind Speed only available if a GPS option is fitted.
N	Knots (NMEA output fixed to Knots measurement only).
A	Acceptable measurement (V is a void fail measurement).
0C	Hex Check Sum.

Immediately followed by:-

\$WIXDR,C,+023.9,C,TEMP,P,1.0243,B,PRESS,H,039,P,RH,Y,000.0,M,PRECIP\*01<CR><LF>.

Where: -

\$WIXDR	Wind Instrument Transducer
C	Type of Sensor (Temperature)
+023.9	Temperature Reading
C	Temperature Reading in Degrees Centigrade
TEMP	Name of Temperature Sensor
P	Type of Sensor (Pressure)
1.0243	Pressure Reading in Bars.
B	Pressure Units of Measure (Bars)
PRESS	Name of Pressure Sensor
H	Type of Sensor (Humidity)
039	Humidity Reading in Percent
P	Humidity Units of Measure (Percent)
RH	Name of Relative Humidity Sensor
Y	Type of Sensor (Precipitation)
000.0	Millimetres per hour of Precipitation
M	Precipitation Units of Measure (Millimetres)
PRECIP	Name of Precipitation Sensor
*01	Hex CheckSum

Followed by GPS data if option available.

\$GPGGA,161229.487,3723.2475,N,12158.3416,W,1,07,1.0,9.0,M, , , ,0000\*18<CR><LF>.

Where

\$GPGGA	NMEA GPS Protocol Header
161229.487	UTC Time, hhmmss.sss
3723.2475	Latitude ddmm.mmmm
N	North/South Indicator
12158.3416	Longitude ddmm.mmmm
W	East/West indicator
1	Position Fix Indicator (See below)
07	Satellites being used (Range 0-12)
1.0	Horizontal Dilution of Precision
9.0	Mean Sea Level (NSL) Altitude in Metres
M	MSL Units, Metres
, , , ,	Geoid Separation and Units in Metres
0000	Differential GPS Reference Station ID.
*18	Checksum

Position Fix Indicator:

Value	Description
0	Fix not available or invalid
1	GPS SPS Mode, fix valid
2	Differential GPS, SPS Mode, fix valid
3-5	Not supported
6	Dead Reckoning Mode, fix valid

<CR> is a Carriage return character (ASCII hex value d)

<LF> is a Line Feed Character (ASCII hex value a)

Checksum, the 2 digit Hex Checksum sum figure is calculated from the Exclusive OR of the bytes between (and not including) the \$ and \* characters.

Example GMX 600 Data.

```
$WIMWV,069,R,004.06,N,A*00  
$WIMWV,122,T,,N,A*14  
$WIXDR,C,+023.2,C,TEMP,P,1.0281,B,PRESS,H,037,P,RH,Y,000.0,M,PRECIP*0A  
$GPGGA,075613.000,5045.7954,N,00132.3938,W,1,07,1.2,21.5,M,47.8,M,,0000*7B (GPS unit).
```

Followed 1 second later by

```
$WIMWV,238,R,000.46,N,A*06  
$WIMWV,303,T,,N,A*15  
$WIXDR,C,+023.2,C,TEMP,P,1.0281,B,PRESS,H,037,P,RH,Y,000.0,M,PRECIP*0A  
$GPGGA,075613.000,5045.7954,N,00132.3938,W,1,07,1.2,21.5,M,47.8,M,,0000*7B
```

Followed 1 second later by

```
$WIMWV,130,R,000.21,N,A*0C  
$WIMWV,205,T,,N,A*12  
$WIXDR,C,+023.2,C,TEMP,P,1.0281,B,PRESS,H,038,P,RH,Y,000.0,M,PRECIP*05  
$GPGGA,075613.000,5045.7954,N,00132.3938,W,1,07,1.2,21.5,M,47.8,M,,0000*7B
```

Etc.

## 6.7. Safe Mode

### 6.7.1 Summary

The MaxiMet Safe Mode provides a means of recovering communication with the MaxiMet whatever configuration setting may have been made. For instance if the unit has been set for SDI-12 or Modbus operation Safe Mode can be used to change the communication option back to RS232 or RS422.

### 6.7.2 Safe Mode Method 1

#### Connection

Connect the MaxiMet for RS232 communication as detailed in Para 4.6.

Open Gill MetSet Software (see Para 6.2).

Click on Connect and Read. MetSet will scan COM port settings for a connected MaxiMet but as the COMMS protocol is not matched will be unable initially to find the MaxiMet.

Now Click on the Safe Mode button.

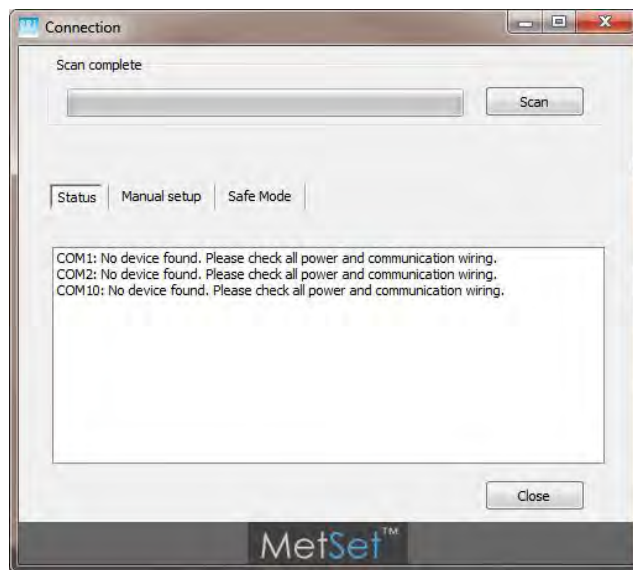

Ensure the MaxiMet is wired for RS232 operation and power and Click on Next.



Enter the MaxiMet COM Port connection number.



Ensure power is now disconnected from the MaxiMet.

**NOTE: If using the Gill Instrument RS232 to USB configuration cable then unplug the 9 way connector from the base of the MaxiMet.**

Now click on Next.

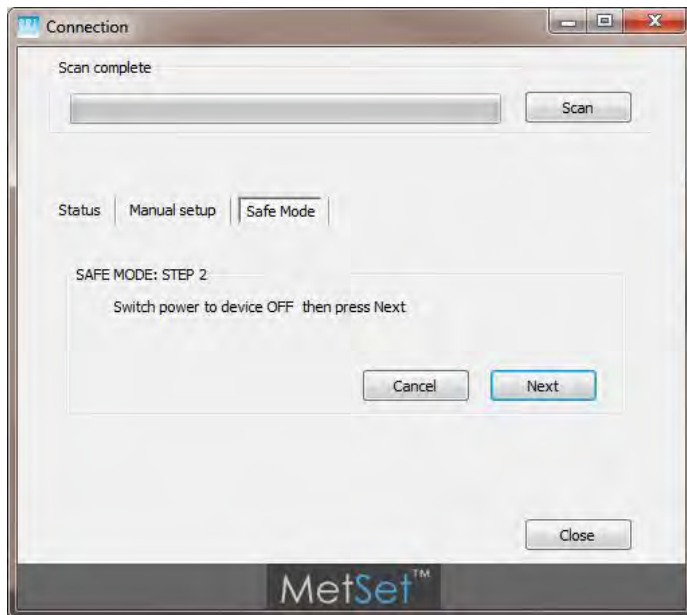

Now re-connect power to the MaxiMet.

**Note: If using the Gill Instrument RS232 to USB configuration cable then plug in the 9 way connector to the base of the MaxiMet.**

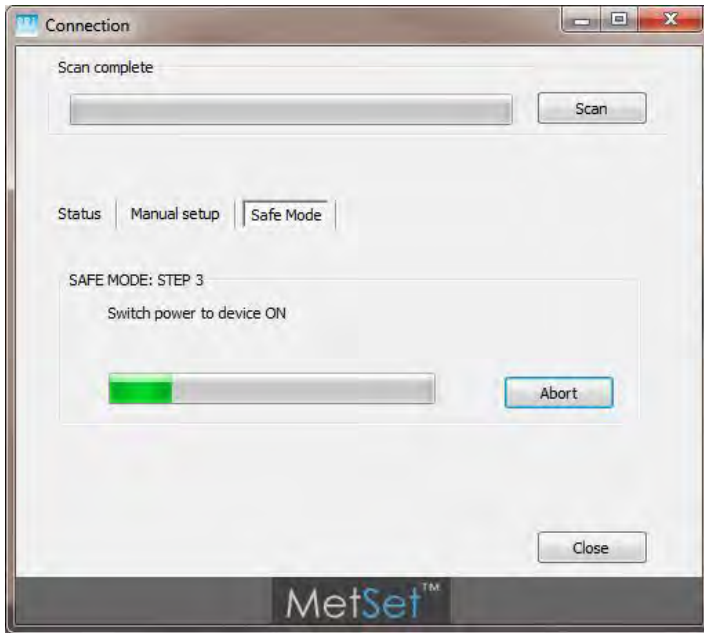

MetSet now opens a Safe Mode 4800 baud connection from which all settings can now be read and changed.

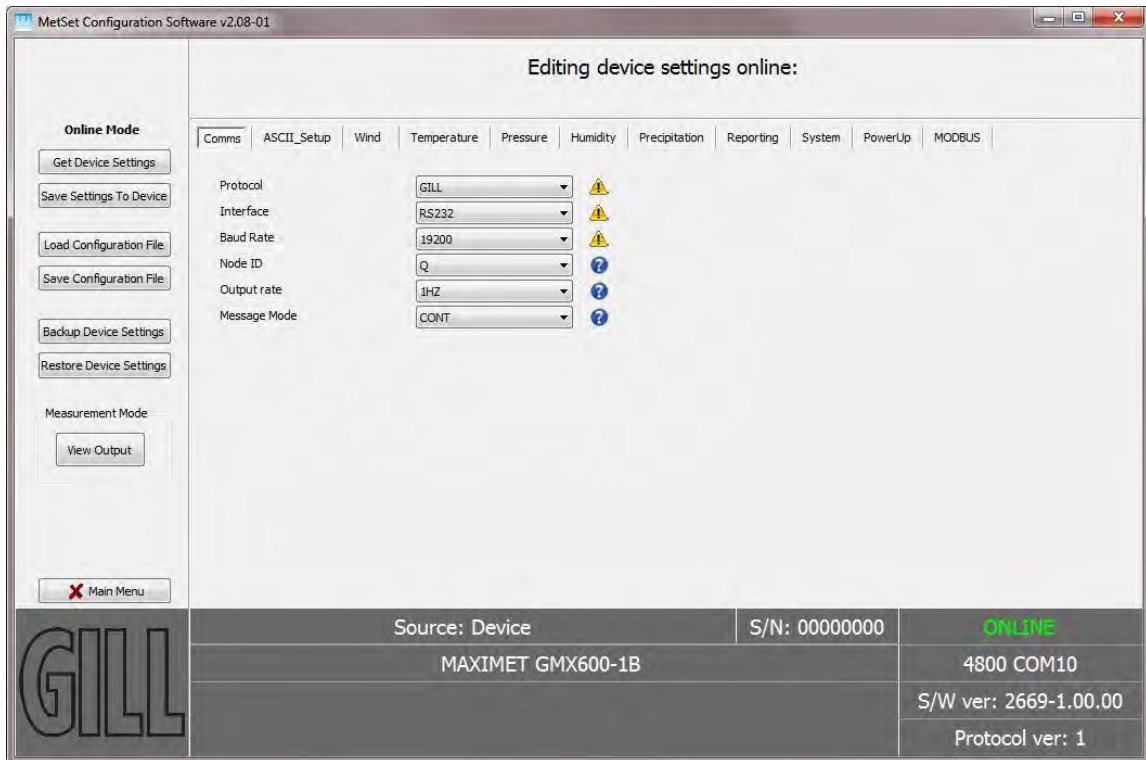

### 6.7.3 Safe Mode Method 2

#### Connection

Connect the MaxiMet for RS232 communication as detailed in Para 4.6.

**Note at this stage the MaxiMet supply to be switched off.**

**If using the Gill Instruments RS232 to USB configuration cable then unplug the 9-way connector from the base of the MaxiMet.**

**Open a Terminal program e.g. Gill WIND Software (obtainable from <http://www.gillinstruments.com/main/software.html> ) or equivalent terminal program e.g. Tera-Term, Putty etc.**

If using Gill Wind Software note that the Tools features are not applicable.

Open Gill Wind Software.

**Serial Port:** Set the drop down menu to the required COM Port Connection.

Click on the **OK** button.

**Baudrate:** Set the drop down menu to **4800** Bauds.

A blank Wind Terminal screen will be opened.

Left Click the mouse in the blank terminal screen.

Hold down the \* key on the keypad.

**With the \* key still held down, apply power to the MaxiMet.**

**If using the Gill Instruments RS232 to USB configuration cable then plug in the 9-way connector to the base of the MaxiMet.**

This will result in placing the unit into SAFE MODE.

Press Enter to start a new line (Ignore illegal command line).

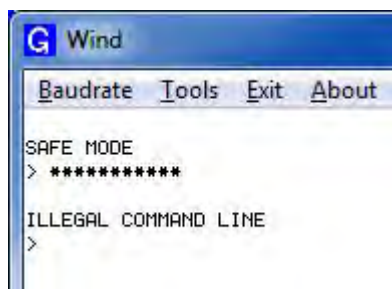

To now change communication from say SDI-12 (or MODBUS) or RS422 or RS485 to Default RS232.

Type COMMS RS232 and press Enter.

Type Q and press Enter to exit SAFE MODE.

Data will now scroll on screen.

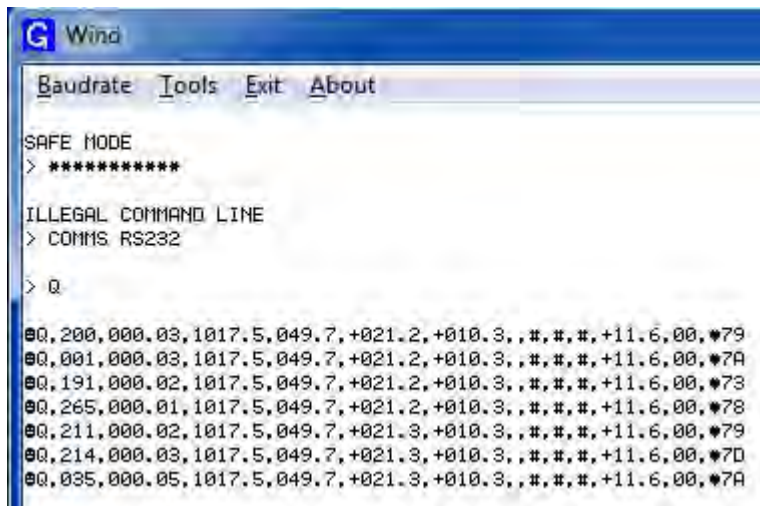

Close the 4800 baud rate Wind or Terminal Program.

**Power down the MaxiMet and re-apply power.**

Open Gill MetSet software and read settings/change settings as required.

## 6.8. Using a Terminal Program to Set MaxiMet Date and Time

As an alternative to using MetSet to set MaxiMet time which might add a delay to time setting as MetSet saves settings (up to 60 seconds) then MaxiMet TIME can be set manually with potentially more accuracy against a reference time as follows:.

1. With the MaxiMet set and wired for RS232 or RS422 data two-way TX/RX communication via a suitable converter, interface the MaxiMet to a PC running a terminal program.
2. Open a terminal program e.g. Gill Wind software (note the Wind software Tools features are not applicable) or Tera Term or Putty etc.
3. Select the required COM port connection e.g. COM 39.

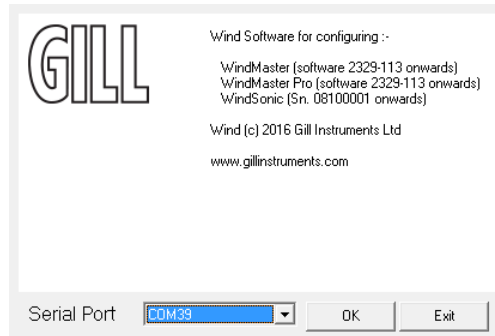

4. Select the baud rate to match the MaxiMet setting (default 19200 baud).
5. MaxiMet data should scroll on screen.

```
Q,027,000.23,311,1018.8,041,+025.4,+011.5,0002,2017-06-01T15:21:30.0,+05.2,0000,18
Q,045,000.14,330,1018.8,041,+025.4,+011.5,0002,2017-06-01T15:21:31.0,+05.2,0000,1A
```

6. Type \* (asterisk) to set the MaxiMet to SETUP MODE.
7. Type TIME and Press the PC Enter key to show the current date and time (and format).

TIME = 2017-06-01T15:25:00

8. To set a new TIME choose a convenient Time in the future say 5 minutes ahead.
9. Now Type in the new Date/Time in the following format:-

TIME 2017-06-01T15:30:00

(Year/Month/Day/Hours/Minutes/Seconds)

10. Using a reference accurate clock/watch showing current time compare this to the time set above.
11. When the two TIMES are matched press the PC Enter key to update the MaxiMet TIME to the reference time.
12. Type Q and press the Enter key to return the MaxiMet to Measurement mode with the updated TIME reading.

## 7. VIEWING MAXIMET DATA STRING

### 7.1. Use MetSet to View the MaxiMet Data String

Install MetSet software on to a PC from the supplied CD or download MetSet from the Gill Website at:-

<http://gillinstruments.com/main/software.html>

MetSet Software allows you to view the MaxiMet data string graphically.

Before you can use MetSet, check that MaxiMet is correctly connected to a Serial COM port or USB COM port on your PC.

**NOTES:** MetSet is compatible with RS232 and RS422 connected units set for ASCII and NMEA output only.

MetSet will not read SDI-12 or MODBUS data strings.

### Opening MetSet

Click on the MetSet **Connect and Read** button:

MetSet will display the Editing Screen.

Now Click on **View Output** button.



The MaxiMet data string will be shown.

Note that this terminal program can only read MaxiMet data it cannot be used to send commands to the MaxiMet.

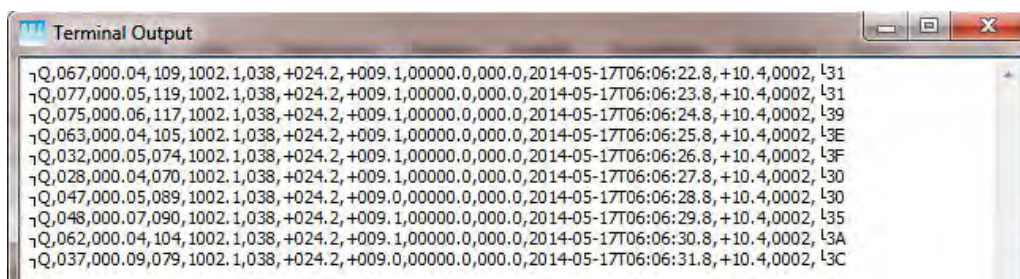

## 7.2. Using Gill MetView Software to View the MaxiMet Data String.

Install MetView software on to a PC from the supplied CD or download MetView from the Gill Website at:- <http://gillinstruments.com/main/software.html>

MetView Software allows you to view the MaxiMet data visually and has a simple data logging facility.

Before you can use MetView, check that MaxiMet Pro is correctly connected to a Serial COM port or USB COM port on your PC.

**NOTE:** MetView is compatible with RS232 and RS422 connected units set for ASCII only.

MetView will not read NMEA, SDI-12 or MODBUS data strings.

**Requires the use of MetView Software version 2.04-05 and higher to read MaxiMet data.**

### 7.2.1 Opening MetView

Click on the MetView button on your PC's desktop or choose:

**Start > Programs > MetView > MetView**

The MetView Control Centre window is displayed as follows:-

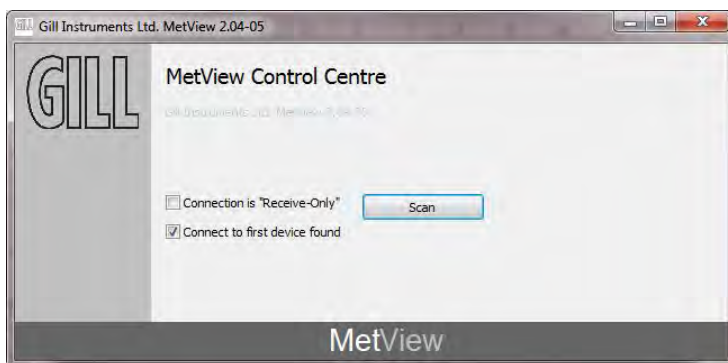

**Connection is Receive Only Tick Box** – Use (tick) if the MaxiMet connection to the PC has only transmit wires connected and a MetSet version of its current device settings is available to upload to MetView. Select 'Connection is Receive only' tick box and click on the Scan button. Upload a MetSet generated Device file from a PC location as directed.

**Connect to first device found** – Selecting this box (default setting) means that if multiple MaxiMets are connected to the PC the MetView will connect to the lowest COM port number connected MaxiMet first.

If the Connect to first device option is not selected then all connected MaxiMet COM port connections will be shown when the Scan button is selected.

**Scan Button**– If MaxiMet transmit and receive wires are connected to the PC then use the Scan button to connect to MetView.

## 7.2.2 Scanning for Devices

To set up communicate between MetView and a connected MaxiMet:

Click on the **Scan** button to search the available COM ports for connected MaxiMet units.

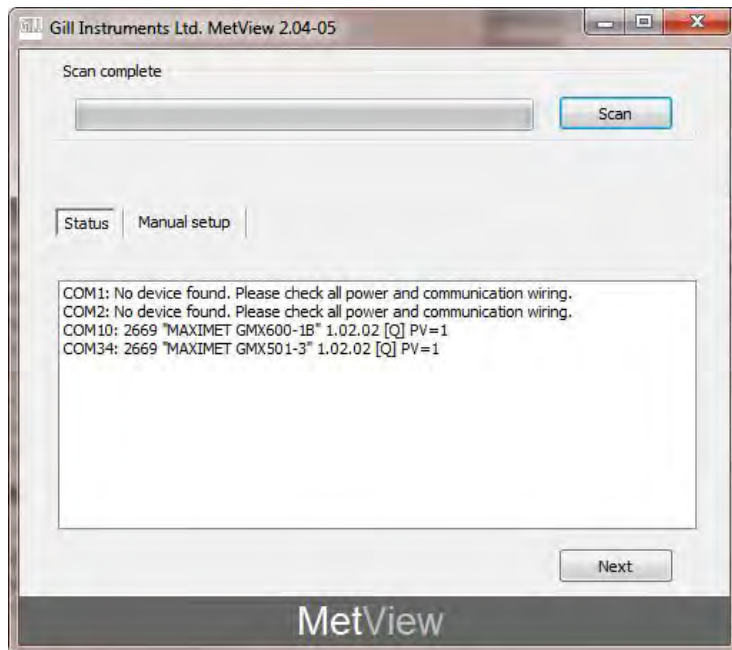

If **Connect to first device found** has been selected then MetView will automatically connect to the MaxiMet on COM Port 10 (connects to lowest numbers first) and open the MaxiMet data view screen showing all of the MaxiMet parameters that have been enabled as outputs.

If **Connect to first device found is deselected** then click on the Scan button.

MetView will then allow the required MaxiMet connection to be made using the blue background highlighted drop down menu.

Select Connect to go to the Data view screen.

To select the other MaxiMet then in the Data view screen select the Disconnect button and use the drop down menu below to select and connect to the new MaxiMet.

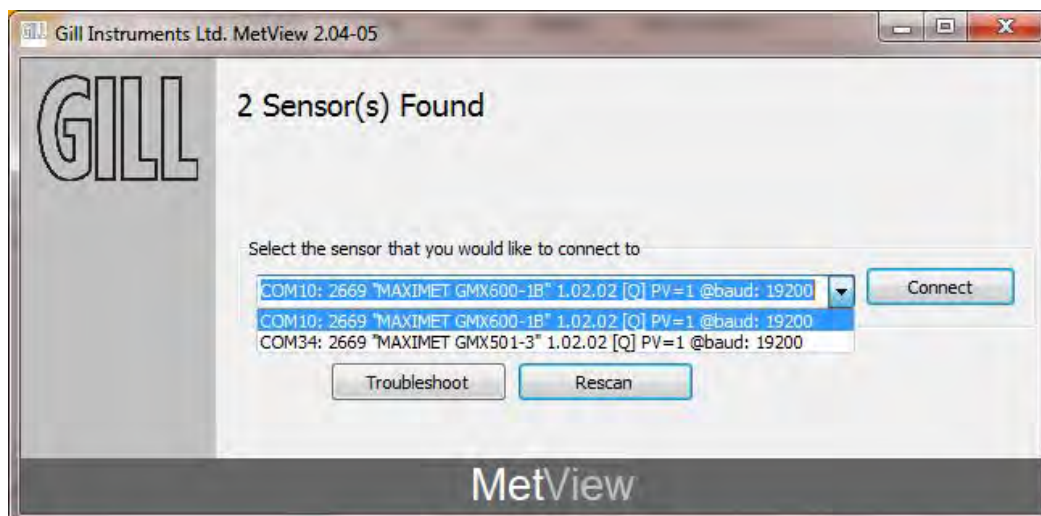

### 7.2.3 The MetView Console

When connected correctly, MetView displays its data-monitoring console. This consists of gauges for all of MaxiMet enabled parameters.

Buttons beneath each of the gauges allow you to choose the displayed units and other options. Each gauge also shows the maximum and minimum values recorded during the current session. The wind speed gauge also shows the maximum gust speed.

Note: MetView will not show data if the unit is set for MODBUS or SDI-12 format.

An example MetView screen (part of) is shown below (GMX600 default output).



#### Connection status indicators

Reading	Function
Green Background Tick	Indicates that the MaxiMet is logging or communicating correctly with MetView along with reading the MaxiMet firmware version.
Red Background Cross	Indicates that the MaxiMet is not logging or connected/communicating with MetView.
1.00Hz	Indicates the output rate of the MaxiMet when connected. Reads when the unit is communicating correctly with MetView.
Wed 05 Aug 2015 12:34:45	Real Time PC date and time indication.

Remaining MetView GMX600 default output screen shown below.



#### Notes.

No gauges are associated with the above digital readouts.

The order in which the instruments are shown in the MetView display reflects the order in which the instrument data appears in the MaxiMet data string.

## 7.2.4 MetView Console Display Options

Units shown in **bold** on the MetView screen denote default settings.

### MetView Scale and Units of Measure Options

MetView Console buttons can convert data from the MaxiMet to read different units of measure or scale settings or in the case of Wind readings the type of display (e.g. Maritime , NSEW).

On screen MetView settings do not alter the actual MaxiMet configuration settings or MaxiMet logged data parameters and units of measure.

### MetView Averaging Options

Setting	Function
<b>Real Time</b>	Choose this button for no averaging
2 Min	Select for on screen 2 minute rolling average for all sensor readings
10Min	Select for on screen 10 minute rolling average of all sensor readings

### MetView Max/min markers

Setting	Function
<b>Off</b>	Maximum and Minimum Markers on all applicable gauges turned off
On	Maximum and Minimum Markers on all applicable gauges turned on
Reset	Reset all applicable Gauge Maximum/Minimum Markers and all digital Maximum/Minimum reading at will

### MetView Screen Settings Options

Setting	Function
Save Settings	Will Save all the current MetView screen settings to a file location as a .msf file for later retrieval if required.
Load Settings	Will Load and update the MetView screen with a previously saved .msf file setting. For use when only a MaxiMet Transmit connection is available
Default Settings	Will return all MetView screen settings to factory default.

### 7.2.5 MetView Gauge Ranges and Graphs

#### Gauge Range Settings.

MetView thermometer style gauge ranges may be altered to view changes in sensor readings more visibly.

Note, these changes only affect MetView settings and do not affect the MaxiMet output or logged data.

For instance if the typical temperature measurement range required is from 0 degrees to +30 degrees C then the temperature gauge range can be adjusted to reflect this.

Place the mouse pointer over the Temperature display gauge and double click to bring up the Set Gauge Range screen. Change Min and Max readings to required values, e.g. 0 Min and +30 Max. Click on Set.

The Temperature gauge range will be updated to reflect the change.

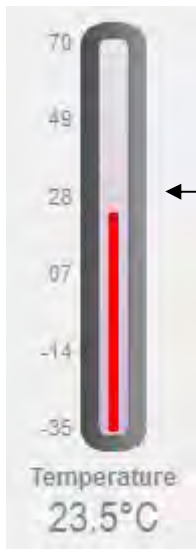

Double Click here to bring up Set Gauge Range.



Change on screen range settings as required.

E.g. Min to 0 and Max to 30 degrees C.

Click on the Set button.

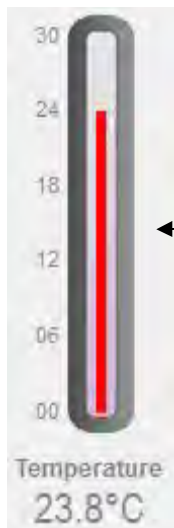

After changing the Gauge Range.

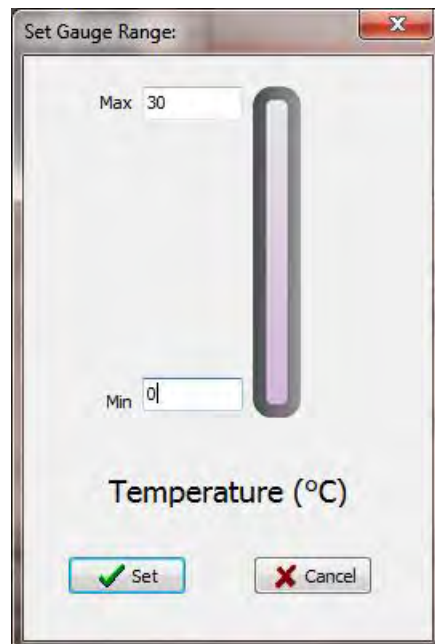

## Graphs

MetView allows data detected over the last minute, last 1 hour and last 24 hours to be accessed and shown on a graph.

**Note.** Data is only shown up to the time when the graph function is selected; the graph is not updated once opened. Data is collected from the time that MetView is opened and reading data from a MaxiMet.



Double Click on the reading to bring up the graph.

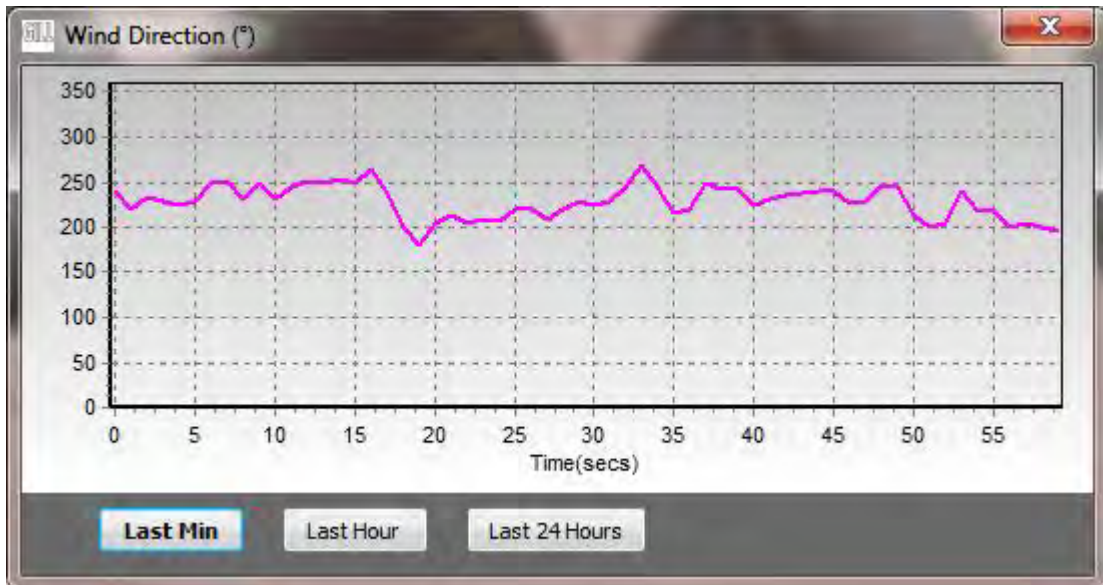

Click on the Last Min, Last Hour or Last 24 Hours buttons as required to view data.

## 7.2.6 Data logging

**NOTE.** MetView logs data based on the MaxiMet configuration not on the MetView console settings.

### Start

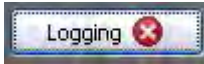
Click on the **Logging** button  on the opening MetView console.

The Logging dialog box is displayed.

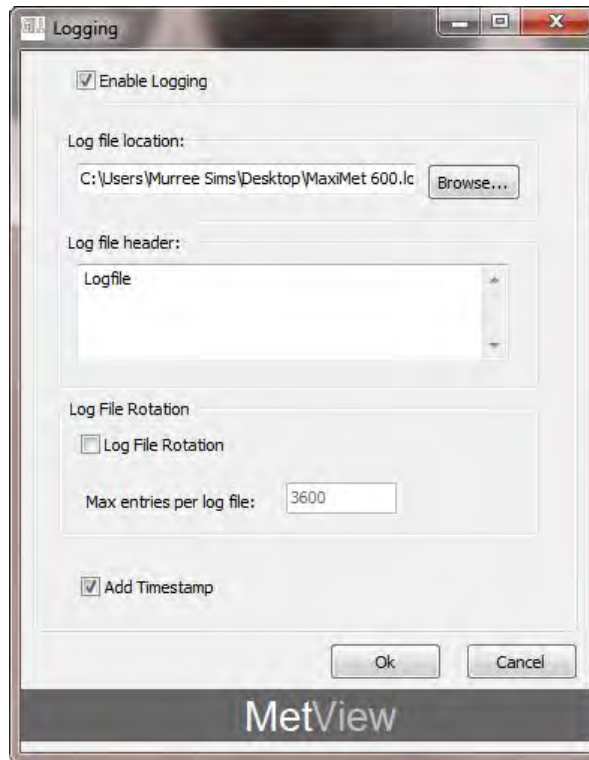

**Set up a logging file -** Select **Enable Logging** (adds a tick to the box).

**Log File location -** Click on the **Browse** button to identify the folder where you want to store the data file. Enter the name of the file.

**Log file header -** If required type some notes on the data that is to be recorded which will appear at the top of the saved data log file.

**Log File Rotation -** Set up segmented logging with each logged file length determined by the number entered in the text box below. The figure 3600, for example, means that each log file length will be 3600 lines of data. Maximum entries per log file is limited to 65535 and a maximum of 2048 log files can be created.

**Add Timestamp -** Select to add date and time to the logged data file taken from the PC clock.

**To start logging** Check that the **Enable Logging** option is selected.

Click on the **OK** button to commence logging and return to the console.

**Note.** To show that data is being recorded, the Logging button's icon changes from a cross with a red background to a tick with a green background.

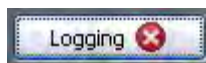

**To stop logging -** Click on the **Logging** button on the MetView console. Clear the **Enable Logging** check box.

Click on the **OK** button. If logging has stopped, the Logging button shows a red background cross instead of the green background tick (see above).

An example of the logged MaxiMet data .log file opened by Notepad is shown following.

```

maximet 600 log00017.log - Notepad
File Edit Format View Help
logfile
000000,Tue 28 Jul 2015 02:48:56,-0.353,000.02,306,000,000.00,000,000.09,000,0000,1005.9,1005.9,1005.9,044,+021.3,+008.8,08.35,000000.0,000.0,N,313,2015-07-28T02:46:52.8,+05.1,0000,+79
000001,Tue 28 Jul 2015 02:48:57,-0.349,000.03,301,000,000.00,000,000.09,000,0000,1005.9,1005.9,1005.9,044,+021.3,+008.8,08.36,000000.0,000.0,N,312,2015-07-28T02:46:53.8,+05.1,0000,+79
000002,Tue 28 Jul 2015 02:48:58,-0.346,000.02,298,000,000.00,000,000.09,000,0000,1005.9,1005.9,1005.9,044,+021.3,+008.8,08.35,000000.0,000.0,N,312,2015-07-28T02:46:54.8,+05.1,0000,+72
000003,Tue 28 Jul 2015 02:48:59,-0.008,000.02,320,000,000.00,000,000.09,000,0000,1005.9,1005.9,1005.9,044,+021.3,+008.8,08.35,000000.0,000.0,N,313,2015-07-28T02:46:55.8,+05.1,0000,+78
000004,Tue 28 Jul 2015 02:49:00,-0.027,000.02,319,000,000.00,000,000.09,000,0000,1005.9,1005.9,1005.9,044,+021.3,+008.8,08.35,000000.0,000.0,N,312,2015-07-28T02:46:56.8,+05.1,0000,+78
000005,Tue 28 Jul 2015 02:49:01,-0.034,000.02,346,000,000.00,000,000.09,000,0000,1005.9,1005.9,1005.9,044,+021.3,+008.8,08.35,000000.0,000.0,N,312,2015-07-28T02:46:57.8,+05.1,0000,+75
000006,Tue 28 Jul 2015 02:49:02,-0.026,000.02,339,000,000.00,000,000.09,000,0000,1005.9,1005.9,1005.9,044,+021.3,+008.8,08.35,000000.0,000.0,N,313,2015-07-28T02:46:58.8,+05.1,0000,+70
000007,Tue 28 Jul 2015 02:49:03,-0.016,000.03,329,000,000.00,000,000.09,000,0000,1005.9,1005.9,1005.9,044,+021.3,+008.8,08.35,000000.0,000.0,N,313,2015-07-28T02:46:59.8,+05.1,0000,+72
000008,Tue 28 Jul 2015 02:49:04,-0.000,000.03,312,000,000.00,000,000.09,000,0000,1005.9,1005.9,1005.9,044,+021.3,+008.8,08.35,000000.0,000.0,N,312,2015-07-28T02:47:00.8,+05.1,0000,+71
000009,Tue 28 Jul 2015 02:49:05,-0.358,000.03,310,000,000.00,000,000.09,000,0000,1005.9,1005.9,1005.9,044,+021.3,+008.8,08.35,000000.0,000.0,N,312,2015-07-28T02:47:01.8,+05.1,0000,+7C
000010,Tue 28 Jul 2015 02:49:06,-0.353,000.03,306,000,000.00,000,000.09,000,0000,1005.9,1005.9,1005.9,044,+021.3,+008.8,08.35,000000.0,000.0,N,313,2015-07-28T02:47:02.8,+05.1,0000,+72
000011,Tue 28 Jul 2015 02:49:07,-0.005,000.02,318,000,000.00,000,000.09,000,0000,1005.9,1005.9,1005.9,044,+021.3,+008.8,08.35,000000.0,000.0,N,313,2015-07-28T02:47:03.8,+05.1,0000,+7C
000012,Tue 28 Jul 2015 02:49:08,-0.030,000.02,342,000,000.00,000,000.09,000,0000,1005.9,1005.9,1005.9,044,+021.3,+008.8,08.35,000000.0,000.0,N,312,2015-07-28T02:47:04.8,+05.1,0000,+72
000013,Tue 28 Jul 2015 02:49:09,-0.036,000.02,349,000,000.00,000,000.09,000,0000,1005.9,1005.9,1005.9,044,+021.3,+008.8,08.35,000000.0,000.0,N,313,2015-07-28T02:47:05.8,+05.1,0000,+7F
000014,Tue 28 Jul 2015 02:49:10,-0.051,000.02,343,000,000.00,000,000.09,000,0000,1005.9,1005.9,1005.9,044,+021.3,+008.8,08.35,000000.0,000.0,N,314,2015-07-28T02:47:06.8,+05.1,0000,+71
000015,Tue 28 Jul 2015 02:49:11,-0.017,000.03,329,000,000.00,000,000.09,000,0000,1005.9,1005.9,1005.9,044,+021.3,+008.8,08.35,000000.0,000.0,N,312,2015-07-28T02:47:07.8,+05.1,0000,+78
000016,Tue 28 Jul 2015 02:49:12,-0.017,000.02,329,000,000.00,000,000.09,000,0000,1005.9,1005.9,1005.9,044,+021.3,+008.8,08.35,000000.0,000.0,N,312,2015-07-28T02:47:08.8,+05.1,0000,+76
000017,Tue 28 Jul 2015 02:49:13,-0.006,000.02,318,000,000.00,000,000.09,000,0000,1005.9,1005.9,1005.9,044,+021.3,+008.8,08.35,000000.0,000.0,N,313,2015-07-28T02:47:09.8,+05.1,0000,+75
000018,Tue 28 Jul 2015 02:49:14,-0.012,000.02,324,000,000.00,000,000.09,000,0000,1005.9,1005.9,1005.9,044,+021.3,+008.8,08.35,000000.0,000.0,N,312,2015-07-28T02:47:10.8,+05.1,0000,+77
000019,Tue 28 Jul 2015 02:49:15,-0.005,000.03,318,000,000.00,000,000.09,000,0000,1005.9,1005.9,1005.9,044,+021.3,+008.8,08.35,000000.0,000.0,N,313,2015-07-28T02:47:11.8,+05.1,0000,+7F
000020,Tue 28 Jul 2015 02:49:16,-0.013,000.03,325,000,000.00,000,000.09,000,0000,1005.9,1005.9,1005.9,044,+021.3,+008.8,08.35,000000.0,000.0,N,312,2015-07-28T02:47:12.8,+05.1,0000,+74
000021,Tue 28 Jul 2015 02:49:17,-0.013,000.02,326,000,000.00,000,000.09,000,0000,1005.9,1005.9,1005.9,044,+021.3,+008.8,08.35,000000.0,000.0,N,313,2015-07-28T02:47:13.8,+05.1,0000,+76
000022,Tue 28 Jul 2015 02:49:18,-0.016,000.03,328,000,000.00,000,000.09,000,0000,1005.9,1005.9,1005.9,044,+021.3,+008.8,08.35,000000.0,000.0,N,312,2015-07-28T02:47:14.8,+05.1,0000,+7A
000023,Tue 28 Jul 2015 02:49:19,-0.014,000.03,326,000,000.00,000,000.09,000,0000,1005.9,1005.9,1005.9,044,+021.3,+008.8,08.35,000000.0,000.0,N,312,2015-07-28T02:47:15.8,+05.1,0000,+77
000024,Tue 28 Jul 2015 02:49:20,-0.354,000.03,306,000,000.00,000,000.09,000,0000,1005.9,1005.9,1005.9,044,+021.3,+008.8,08.35,000000.0,000.0,N,312,2015-07-28T02:47:16.8,+05.1,0000,+71
000025,Tue 28 Jul 2015 02:49:21,-0.353,000.03,305,000,000.00,000,000.09,000,0000,1005.9,1005.9,1005.9,044,+021.3,+008.8,08.35,000000.0,000.0,N,312,2015-07-28T02:47:17.8,+05.1,0000,+74
000026,Tue 28 Jul 2015 02:49:22,-0.001,000.03,313,000,000.00,000,000.09,000,0000,1005.9,1005.9,1005.9,044,+021.3,+008.8,08.35,000000.0,000.0,N,312,2015-07-28T02:47:18.8,+05.1,0000,+78
000027,Tue 28 Jul 2015 02:49:23,-0.010,000.02,322,000,000.00,000,000.09,000,0000,1005.9,1005.9,1005.9,044,+021.3,+008.8,08.35,000000.0,000.0,N,312,2015-07-28T02:47:19.8,+05.1,0000,+7A
    
```

### 7.3. Use a Terminal Program to View the MaxiMet Data String

There are many terminal programs that might be used to view the MaxiMet data string examples include: HyperTerminal, Putty, Tera Term etc.

If for example Tera Term is used.

Open Tera Term.

Select Serial.

Select MaxiMet connected Com port.

Click on Ok.



Tera Term has opened at 9600 baud and MaxiMet uses 19200 as a default, so change Tera Term Baud Rate setting to 19200.

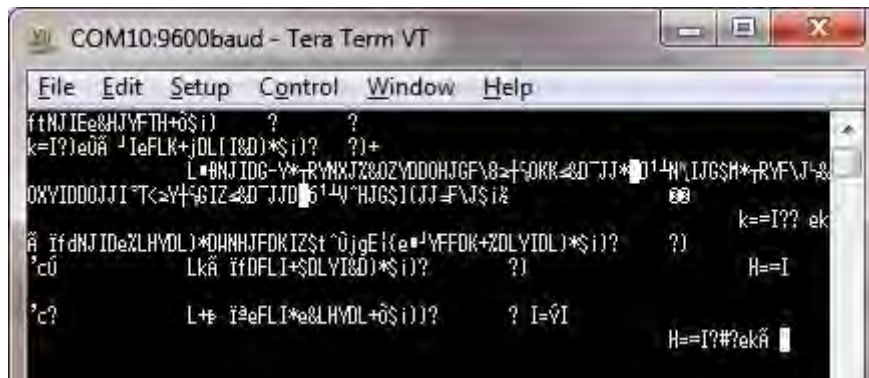

Now select Setup from the top menu.

Click on Serial Port from the drop down menu.

Change Baud rate to 19200.

Click on OK.

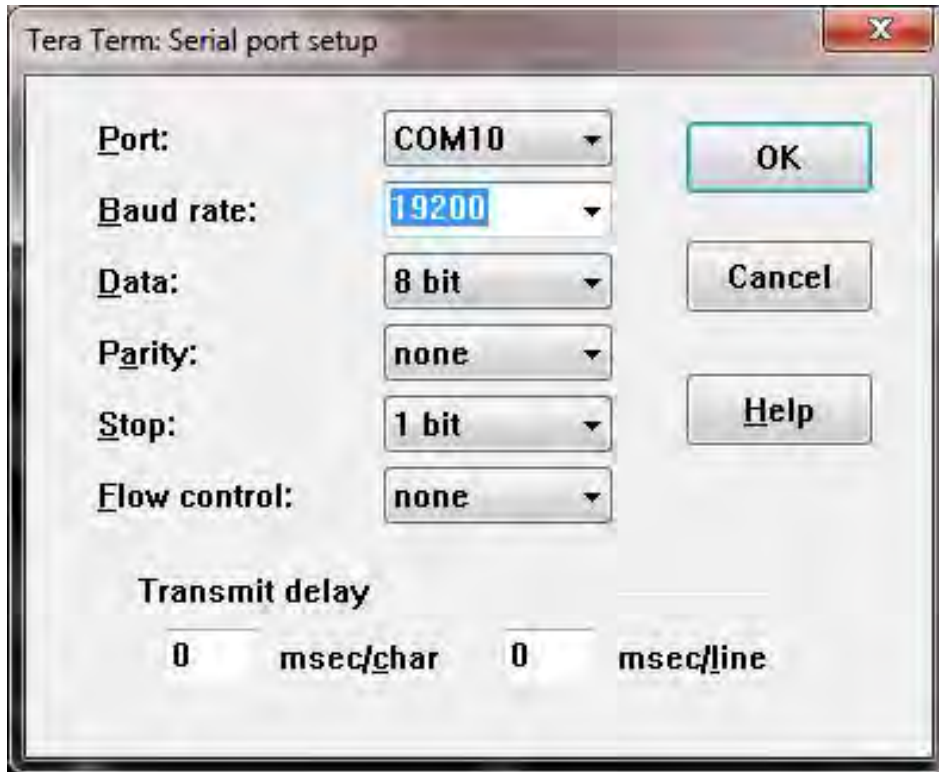

Data will be output as follows.

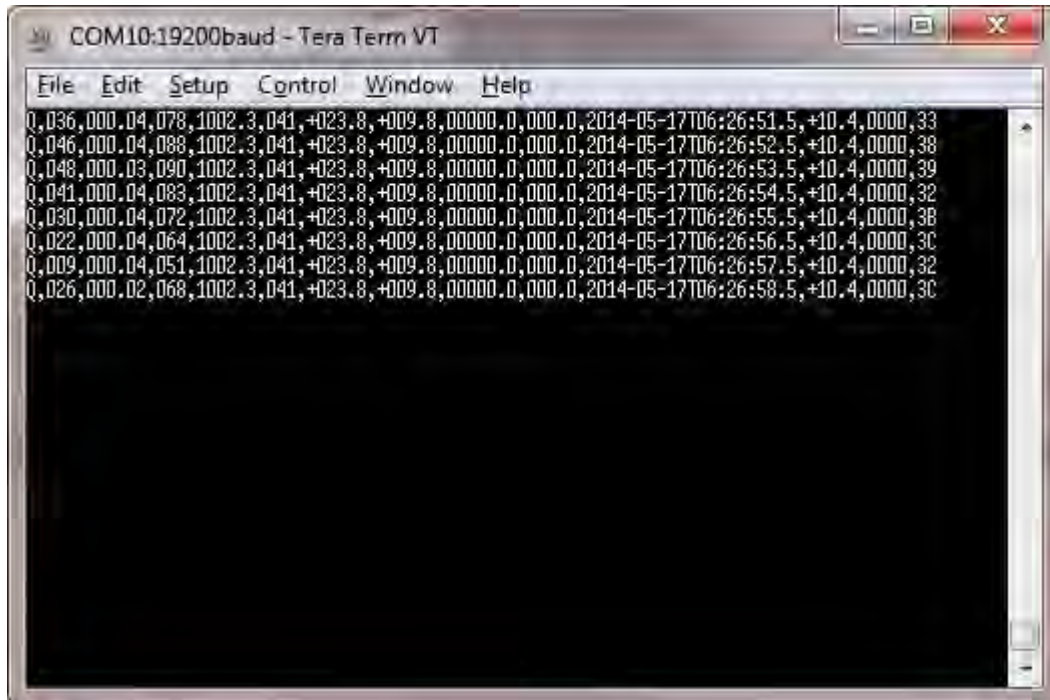

## Setting up a logging file

Select **File/Log**.

**Look in** select a log file location.

Select **Save in** destination. E.g. Desktop.

**File Name** add the name for the file e.g. TeraTerm.

Tick options as required e.g. Timestamp.

Click on **Save**.

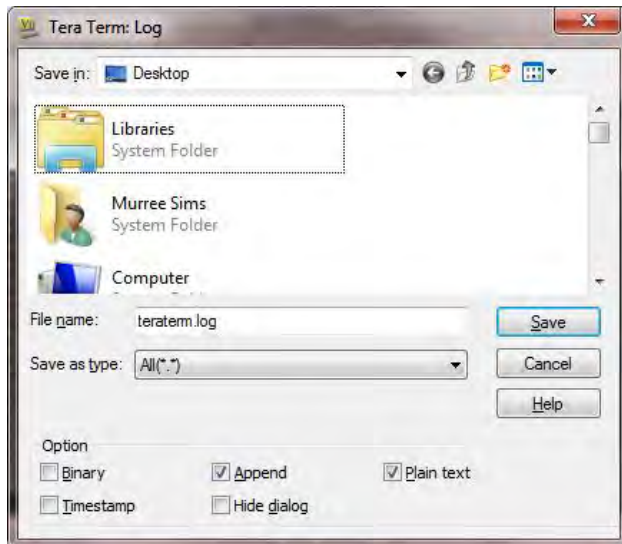

The following dialog box will open on the PC desktop.

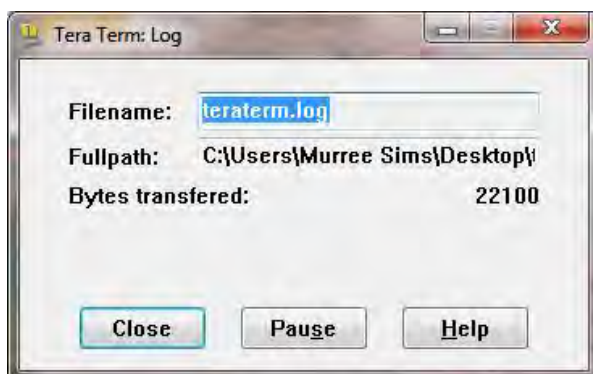

## To stop logging

Click on the **Close** button to Stop Logging.

## Understanding Logged Data

Logged data is stored to a file with a **.log** extension. This can be viewed in any text/HTML editor or spreadsheet application.

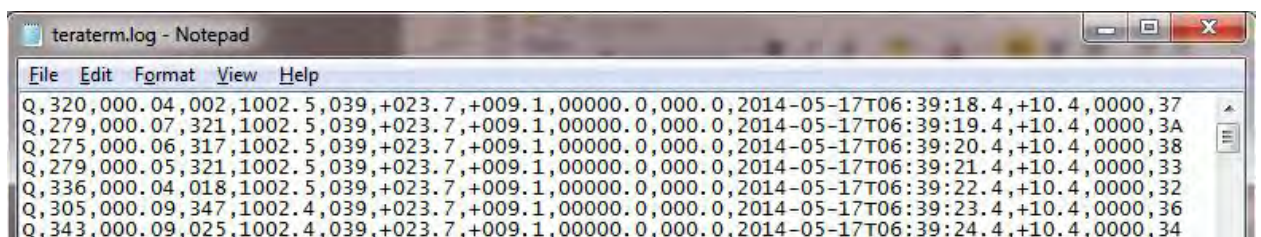

## 8. MAINTENANCE & FAULT-FINDING

### 8.1. Cleaning and Handling

Ideally when installing the unit handle with lint free gloves and degrease the unit to reduce the build-up of deposits.

### 8.2. Servicing

There are no moving parts or user-serviceable parts requiring routine maintenance. Opening the unit or breaking the security seal will void the warranty and the calibration. In the event of failure, prior to returning the unit to your authorised Gill distributor, it is recommended that:

- All cables and connectors are checked for continuity, bad contacts, corrosion etc.
- A bench test is carried out.
- Contact your supplier for advice if failure persists.

#### 8.2.1 Precipitation Sensor.

GMX100, GMX400, GMX600 Solid State Rain Sensor

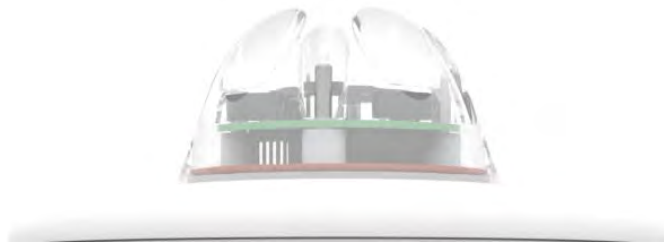

Users/Distributors should clean the plastic dome with a soft lint free cloth and where necessary with a non-aggressive cleaning solution ideally once a week. Where this is not possible, cleaning should be done during regularly scheduled visits to the sensor and site. It is recommended the rain gauge sensor should be cleaned every 3 months as a minimum.

Users can check operation of the rain gauge by performing a simple test of functionality by spraying some water using a mist nozzle similar to that used in many households for watering plants. The MaxiMet rain gauge should register incremental rain fall when sprayed with water.

#### 8.2.2 Solar Sensor.



Users/Distributors should clean the glass dome with a soft lint free cloth and where necessary with a non-aggressive cleaning solution ideally once a week. Where this is not possible, cleaning should be done during regularly scheduled visits to the sensor and site. It is recommended the solar sensor should be cleaned every month as a minimum.

In order to retain compliance with ISO 9060 it is recommended that the solar MaxiMet unit is returned for calibration every 12 months. In general solar calibration should be checked every 24 months as a minimum.

### 8.2.3 Compass/GPS modules.

The Compass and GPS module devices are maintenance free.

If required return the MaxiMet to Gill Instruments to check the Compass and GPS operation.

### 8.2.4 Wind Sensor (WindSonic)

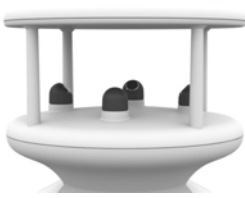

If there is any build-up of deposits on the unit, it should be gently cleaned with a cloth, moistened with soft detergent. Solvents should not be used, and care should be taken to avoid scratching any surfaces. The unit must be allowed to defrost naturally after being exposed to snow or icy conditions, do NOT attempt to remove ice or snow with a tool.

There are no moving parts or user-serviceable parts requiring routine maintenance.

Opening the unit or breaking the security seal will void the warranty and the calibration.

### 8.2.5 Barometer

The Barometer device is located internally and is not maintainable or replaceable by a user.

If required return the MaxiMet to Gill Instruments to check the Barometer calibration.

### 8.2.6 UV Shield (MetSpec)



Ideally the user should try to keep MaxiMet radiation screens clean and free of biological growth but a simple wipe with some non-aggressive soft detergent cleaner will suffice. Solvents should not be used, and care should be taken to avoid scratching any surfaces. The unit must be allowed to defrost naturally after being exposed to snow or icy conditions, do NOT attempt to remove ice or snow with a tool.

### 8.2.7 Temperature, Humidity and Dewpoint

The internal temperature and humidity sensor is not user maintainable or replaceable.

If used in areas of high pollution or marine environments then consideration should be given to returning the unit for maintenance at Gill instruments every 12 to 24 months to ensure proper performance.

### 8.2.8 Calibration

A calibration check can be done by any user/distributor by comparing the values measured by MaxiMet with a reference value or in an environmental chamber. Users should understand that these checks are not the same as the calibration checks or calibration done at Gill but they can provide users with some degree of confidence to the validity of their measurements. If a user/distributor notices a significant difference between the MaxiMet and their test environment/reference they should contact Gill to discuss this and see if a calibration is required. See individual parts above for any recommended calibration periods.

### 8.2.9 Returning the MaxiMet

If the unit has to be returned, it should be carefully packed in the original packaging and returned to your authorised Gill distributor, with a full description of the fault condition. An RMA number should be obtained from Gill Instruments first if returning directly to Gill Instruments.

### 8.3. Fault-finding

Symptom	Solution
No output	<p>Check DC power to MaxiMet, cable and connections.            Check communications settings of the MaxiMet and host system match, including correct Com port.            Check that the unit is in Continuous mode.            Check that in-line communication devices are wired correctly.</p> <p>NOTE: It is usual for Anemometer TX + to be connected to converter device RX +.            If appropriate use Safe Mode to attempt to obtain communication with the MaxiMet.</p>
Corrupted output	<p>Check that the communication settings of the MaxiMet and host system match.            Try a slower baud rate.            Check cable lengths and type of cable.            Check for sources of external signal interference.</p>
One way communication	Check that the wiring is in accordance with the manual.
Unexpected Temperature /Dewpoint readings	Check that the Temperature and Dewpoint units of measure (C, F, K) settings are correct on power up.
Unexpected Wind readings	Check that the Wind Sensor units of measure (m/s, knots, kph, ft/min, mph) settings are correct on power up.
Unexpected Temperature/Dewpoint and Humidity readings	Temperature and Humidity Device faulty.
Unexpected Barometer Readings	Check units of measure are set correctly and if offset HASTN or PSTN readings have been applied.
Unexpected Rainfall readings or no readings when raining	Check in the case of the solid state sensor that the sensor is not obstructed. In the case of a tipping bucket rain gauge check that the funnel and filter are not clogged and are clean. Check that the tipping bucket mechanism swings freely.
Status code not 0000 or A	See following tables.

## Sensor Status Codes

Code	Status	Condition
0000	OK	No fault conditions detected in measurement period.
0001	Wind Measurement Fault	Wind Sensor faulty
0002	GPS Error	E.g. Locating Satellite fix
0004	Source for Corrected Wind Direction is GPS	GPS notification
0006	GPS Location Missing	GPS error
0010	Temperature Measurement Fault.	Temperature sensor faulty
0020	Dewpoint fault	If Temperature and Humidity are reporting correctly then this code indicates a main pcb fault.
0040	Humidity fault	Humidity Sensor faulty.
0080	Pressure Sensor Warning	Pressure sensor reading not available/unit faulty.
0100	Compass fault	Invalid heading due to compass fault

## Wind Status Codes

Code	Status	Condition
0000	OK	No fault conditions detected in measurement period.
0001	Wind Sensor Axis failed	Wind U Axis blocked or faulty
0002	Wind Sensor Axis failed	Wind V Axis blocked or faulty
0004	Wind Sensor both Axis failed	Wind U and V Axis blocked or faulty
000B	Wind Sensor readings failed	Wind Sensor data output fault.
0100	Wind Average Building	WMO wind average building.
0200	Corrected Wind Measurement not available.	Compass corrected wind measurement failure.
A	NMEA Acceptable Data	No fault conditions detected in measurement period.
V	NMEA Void Data	Fault condition detected in measurement period.

## 8.4. Safe Mode

If a unit is received that will not communicate or the configuration settings are not known then Safe Mode can be used to establish communication with the MaxiMet and change configuration settings (see Para 6.7).

## 8.5. Bench Test

See Para 4.10.3.

## 8.6. Returning Units

If the unit has to be returned, it should be carefully packed in the original packaging and returned to your authorised Gill distributor, with a full description of the fault condition.

## 8.7. Guarantee

For terms of guarantee contact your supplier.

Warranty is void if the unit is damaged or broken.

## 9. APPENDICES

### 9.1. Glossary & Abbreviations

Item	Meaning
CAL	Calibration
CR	Carriage Return
CRLF	Carriage Return Line Feed
CSV	Comma Separated Variable
ENG	Engineering
ESC	ESCAPE key on keyboard.
ETX	End of string character
fpm	Feet per minute
GND	GrouND
HEX	HEXadecimal
I/P	InPut
IP66	Protection Classification
KPH	Kilometres per Hour
LF	Line Feed
m/s	Metres per second
MAG	MAGnitude - scalar reference to wind speed
MAX	MAXimum
MIN	MINimum
MPH	Miles per Hour
NMEA 0183 (V3)	National Marine Electronics Association
No:	Number
NVM	Non-Volatile Memory
O/P	Output
PC	IBM compatible Personal Computer
PCB	Printed Circuit Board
ROM	Read Only Memory
RS232	Communications standard
RS422	Communications standard
RS485	Communications standard
RWA	Road Weather Averaging
RX	Receive
RXD	Received Data
S/W	Software
SDI-12	Serial Data Interface
SEC	SECond
STX	Start of string character
TERM	TERMinal
TX	Transmit
TXD	Transmitted Data
+VE	Positive
-VE	Negative
WRT	With Respect To

## 9.2. Electrical Conformity

### EU Declaration of Conformity

---

We **Gill Instruments Limited**  
Of **Saltmarsh Park**  
**67 Gosport Street**  
**Lymington**  
**SO41 9EG**  
**England**



In accordance with the following CE Directives:



**2014-30-EU (Electromagnetic Compliance - EMC)**  
**2011-65-EU (Restriction of Hazardous Substances - RoHS)**

Hereby declare under our sole responsibility that the following products have been designed and where appropriate, manufactured and tested in accordance with the applicable requirements of the following European harmonised standards and where applicable, IEC Standards:

#### 1957 MaxiMet

EMC Emissions & Immunity	<b>EN60945:2002 (Section 11.2)</b> <b>EN61326-2-1:2013</b> <b>ETSI EN301-489-1 V1.9.2</b>
Restriction of Hazardous Substances	<b>EN50581:2012</b>

Signed by:

Print Name: **R. McKay**

Position: **Product Manager**

Date of Issue: **14<sup>th</sup> February 2017**

Place of Issue: **Gill Instruments Ltd, Lymington**

Change Note: **9085**

Doc No: **1957-014**

Issue: **02**

Date: **14/02/2017**